

EN

INSTRUCTIONS
LOCAL AIR CONDITIONER

Table of contents

Information on the use of these instructions 2

Safety 2

Information about the device..... 5

Transport and storage..... 6

Assembly and start-up 7

Operation 10

Errors and faults..... 16

Maintenance 17

Technical annex..... 21

Disposal 25

Simplified EU Declaration of Conformity 25

Information on the use of these instructions

Symbols

 **Danger**
This symbol indicates dangers to the life and health of persons due to extremely flammable gas.

 **Warning**
This signal word indicates a hazard with an average risk level which, if not avoided, can result in serious injury or death.

 **Warning of electrical voltage**
This symbol indicates dangers to the life and health of persons due to electrical voltage.

Notice
This signal word indicates important information (e.g. material damage), but does not indicate hazards.

 **Info**
Information marked with this symbol helps you to carry out your tasks quickly and safely.

 **Follow the manual**
Information marked with this symbol indicates that the instructions must be observed.

You can download the current version of these instructions via the following link:

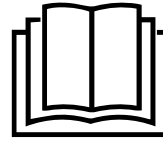

PAC 4100 SH



<https://hub.trotec.com/?id=47713>

Safety

Read this manual carefully before starting or using the device. Always store the manual in the immediate vicinity of the device or its site of use.

-  **Warning**
Read all safety warnings and all instructions. Failure to follow the warnings and instructions may result in electric shock, fire and/or serious injury. **Save all warnings and instructions for future reference.**
- This appliance can be used by children aged from 8 years and above and persons with reduced physical, sensory or mental capabilities or lack of experience and knowledge if they have been given supervision or instruction concerning use of the appliance in a safe way and understand the hazards involved. Children shall not play with the appliance. Cleaning and user maintenance shall not be done by children without supervision.
- Do not use the device in potentially explosive rooms or areas and do not install it there.
 - Do not use the device in an aggressive atmosphere.
 - Place the device in an upright and stable position on a horizontal and stable surface.
 - Let the device dry out after a wet clean. Do not operate it when wet.
 - Do not use the device with wet or damp hands.
 - Do not expose the device to directly squirting water.
 - Never insert any objects or limbs into the device.
 - Do not cover the device during operation.
 - Do not sit on the device.
 - This appliance is not a toy. Keep away from children and animals.
 - Check accessories and connection parts for possible damage prior to every use of the device. Do not use any defective devices or device parts.

- Ensure that all electric cables outside of the device are protected from damage (e.g. caused by animals). Never use the device if electric cables or the power connection are damaged!
- The mains connection must correspond to the specifications in the Technical annex.
- Insert the mains plug into a properly fused mains socket.
- Observe the technical data when selecting extensions to the power cable. Completely unroll the extension cable. Avoid electrical overload.
- Before carrying out maintenance, care or repair work on the device, remove the mains plug from the mains socket. Hold onto the mains plug while doing so.
- Switch the device off and disconnect the power cable from the mains socket when the device is not in use.
- Do not under any circumstances use the device if you detect damages on the mains plug or power cable. If the supply cord is damaged, it must be replaced by a special cord or assembly available from the manufacturer or its service agent.
Defective power cables pose a serious health risk!
- When positioning the device, observe the minimum distances from walls and other objects as well as the storage and operating conditions specified in the Technical annex.
- Make sure that the air inlet and outlet are not obstructed.
- Do not remove any safety signs, stickers or labels from the device. Keep all safety signs, stickers and labels in legible condition.
- Make sure that the suction side is kept free of dirt and loose objects.
- Only transport the device in an upright position with an emptied condensation tray or drain hose.
- Discharge the collected condensate before transport and storage. Do not drink it. Health hazard!
- Use batteries of type AAA.
- Do not insert rechargeable batteries into the remote control.
- Never charge batteries that cannot be recharged.
- Different types of batteries and new and used batteries must not be used together.
- Insert the batteries into the battery compartment according to the correct polarity.
- Remove discharged batteries. Batteries contain materials hazardous to the environment. Dispose of the batteries according to the national regulations.
- Remove the batteries from the remote control if you will not be using the device for a longer period of time.
- Never short-circuit the terminals of batteries!
- Do not swallow batteries! If a battery is swallowed, it can cause severe internal burns within 2 hours! These burns can lead to death!
- If you think batteries might have been swallowed or otherwise entered the body, seek medical attention immediately!
- Keep new and used batteries and an open battery compartment away from children.
- If the battery compartment does not close securely, stop using the product via the remote control.



Safety warnings for devices containing flammable refrigerants



Warning

Do not drill into or burn.



Warning

Do not use any means other than those recommended by the manufacturer for accelerating the defrosting process or cleaning the device.



Warning

Every person working with or at the refrigerant circuit must be able to provide a certificate of qualification issued by a body accredited by the industry, demonstrating their competence in the safe use of refrigerants based on a procedure well-known in the industry.

- Store the appliance in a room without continuously operating open flames (for example an operating gas appliance) or other potential ignition sources (for example an operating electric heater, hot surfaces);
- Please note that the refrigerant is odourless.
- Only install the device in compliance with the national installation regulations.
- Please observe the local regulations.
- Observe the national regulations for gas installations.
- Only install, operate and store the device PAC 4100 SH in a room measuring more than 11 m².
- Store the device in a way that no mechanical damage can occur.
- R290 is a refrigerant that complies with European environmental regulations. No part of the cooling circuit may be perforated.
- Observe the maximum refrigerant capacity in the technical data.
- Service work may only be carried out in accordance with the manufacturer's specifications. If maintenance and repair work require the support of additional persons, the person trained in handling flammable refrigerants shall continuously supervise the work carried out.

- The entire refrigerant circuit is a maintenance-free, hermetically sealed system and may only be maintained or repaired by specialist companies for cooling and air-conditioning or by the manufacturer.

Intended use

Only use the device for cooling, ventilating, dehumidifying and heating indoor air whilst adhering to the technical data.

Any use other than the intended use is regarded as misuse.

Reasonably foreseeable misuse

- Do not place the device on wet or flooded ground.
- Do not place any objects, e.g. clothing, on the device.
- Do not use outdoors.
- Never immerse the device in water.
- Do not make any unauthorised modifications, alterations or structural changes to the device.
- Do not use the device in the immediate vicinity of swimming pools, bathtubs and showers.

Personnel qualification

People who use this device must:

- have read and understood the instructions, especially the Safety chapter.

Maintenance tasks which require the housing to be opened must only be carried out by specialist companies for cooling and air-conditioning or by the manufacturer.

Safety signs and labels on the device

Notice

Do not remove any safety signs, stickers or labels from the device. Keep all safety signs, stickers and labels in legible condition.

The following safety signs and labels are attached to the device:

WARNING • WARNUNG • ATTENTION

DE Das Gerät muss in einem Raum mit einer Grundfläche größer als 11 m² aufgestellt, betrieben und gelagert werden.

EN Appliance shall be installed, operated and stored in a room with floor area larger than 11 m².

FR L'appareil doit être installé, utilisé et entreposé dans une pièce avec une surface supérieure à 11 m².

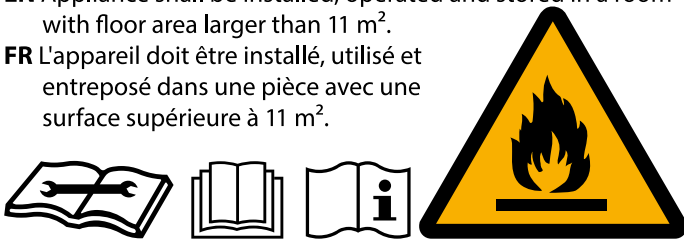

 **Follow the manual**
This symbol indicates that the instructions must be observed.

 **Follow the repair manual**
Disposal, maintenance and repair work of the refrigerant circuit may only be carried out in accordance with the manufacturer's specifications and by persons having a certificate of qualification. A corresponding repair manual is available from the manufacturer upon request.

!!! ACHTUNG !!!

1. Vor Inbetriebnahme MIND. 12 STUNDEN aufrecht und still stehen lassen! Das schützt den Kompressor, verlängert die Lebensdauer erheblich und verhindert so einen Verlust der Kühlleistung.
2. Das Klimagerät muss immer BESONDERS VORSICHTIG auf den Boden gestellt werden! Ansonsten können Mikrorisse in der Bodenplatte und der Kondensatwanne entstehen, was dazu führt, dass Kondenswasser auf den Boden tropft.

Für Schäden, die durch unsachgemäßen Gebrauch entstehen, übernehmen wir KEINE GEWÄHRLEISTUNG!

!!! WARNING !!!

1. Before operation, stand upright and rest for MIN 12 HOURS! This protects the compressor, greatly extending its life and preventing loss of cooling performance.
2. The air conditioner must always be placed on the floor with CAUTION! Otherwise, microcracks may form in the bottom plate and the condensate pan, causing condensation to drip onto the floor.

For damages caused by improper use, WARRANTY WILL BE NULL AND VOID!

!!! ATTENTION !!!

1. Avant la mise en service, laisser immobile en position verticale PENDANT AU MOINS 12 HEURES ! Cela protège le compresseur, prolonge sensiblement la durée de vie et évite ainsi une diminution des performances de refroidissement.
2. Le climatiseur doit toujours être posé sur le sol AVEC LES PLUS GRANDES PRÉCAUTIONS ! Sinon, des micro-fissures risquent de se former dans le socle ou le bac de récupération de l'eau de condensation, ce qui entraînerait que cette dernière coule sur le sol.

Toute utilisation incorrecte ou non conforme entraîne L'EXTINCTION DE LA GARANTIE !

Residual risks



Danger

Natural refrigerant propane (R290)!

H220 – Extremely flammable gas.

H280 – Contains gas under pressure; may explode if heated.

P210 – Keep away from heat, sparks, open flames and other ignition sources. No smoking.

P377 – Leaking gas fire: Do not extinguish, unless leak can be stopped safely.

P410+P403 – Protect from sunlight. Store in a well-ventilated place.



Warning of electrical voltage

Risk of electric shock!

Risk of an electric shock if the device comes into contact with water!

Do not use this device in the immediate vicinity of bathtubs, showers or swimming pools!



Warning of electrical voltage

Work on the electrical components must only be carried out by an authorised specialist company!



Warning of electrical voltage

Before any work on the device, remove the mains plug from the mains socket!

Do not touch the mains plug with wet or damp hands.

Hold onto the mains plug while pulling the power cable out of the mains socket.



Warning of electrical voltage

Risk of electric shock!

The device is not protected against water.

There is a risk of electric shock!

Never use the device in areas where dripping, spraying or running water can enter the device! Never immerse the device in water!

Notice

Do not operate the device without an inserted air filter!

Without the air filter, the inside of the device will be heavily contaminated. This could reduce the performance and result in damage to the device.

Behaviour in the event of an emergency

1. Switch the device off.
2. Disconnect the device from the mains by removing the mains plug from the socket. When doing so, be sure to hold the plug, not the cable.
3. Do not reconnect a defective device to the mains.

Information about the device

Device description

The device serves the purpose of cooling the room air. It further filters and dehumidifies the air thus creating an agreeable room climate. Additionally, the device can be used as heater.

The device cools the room air by withdrawing warmth. The absorbed warmth is emitted to the outside via the exhaust air hose; cooled air is fed to the installation site by means of a fan.

Accumulating condensate drips from the evaporator onto the hot condenser, there it evaporates and then is transported to the outside via the exhaust air hose.

In *ventilation* mode the device provides the opportunity of air circulation without cooling effect.

In *dehumidification* mode moisture is withdrawn from the air.

In *heating* mode the room air is warmed up.

The device operates fully automatically and features a variety of further options. The device can, for instance, be switched on or off automatically with time delay via the timer function.

Operation of the device is possible either via the control panel at the device or via the supplied infrared remote control. The device can also be operated via a WiFi connection and the Trotec Assistant app.

The device was designed for universal and flexible application.

Due to its compact dimensions it can be easily transported and used in all interior spaces.

The device is protected against vertically dripping water (IPX1).

Device depiction

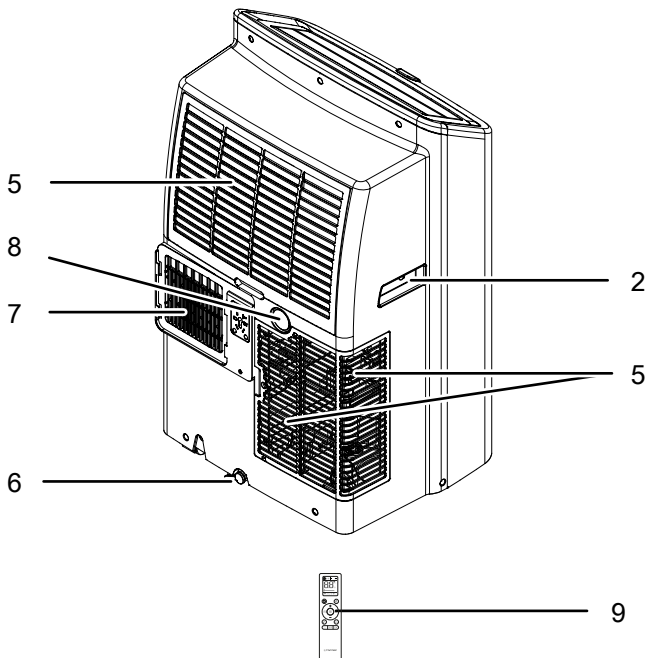
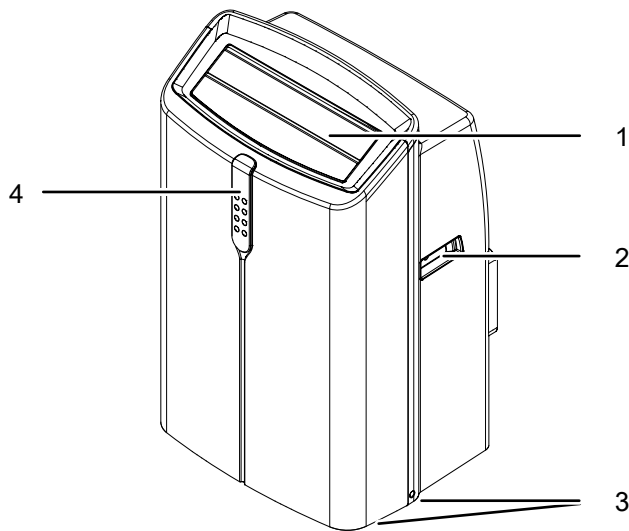

Transport and storage

Notice

If you store or transport the device improperly, the device may be damaged.
 Note the information regarding transport and storage of the device.

Transport

Please note that additional transport regulations might apply to devices containing flammable refrigerants. The equipment's arrangement and the maximum number of components to be transported together can be gathered from the applicable transport regulations.

To make the device easier to transport, it is fitted with wheels.
 To make the device easier to transport, it is fitted with a handle.

Before transporting the device, observe the following:

- Switch the device off.
- Disconnect the device from the mains by removing the mains plug from the socket. When doing so, be sure to hold the plug, not the cable.
- Drain the remaining condensate from the device.
- Do not use the power cable to drag the device.
- Only wheel the device on firm and level surfaces.

After transporting the device, proceed as follows:

- Set up the device in an upright position after transport.
- Leave the device to rest for at least 12 hours, so the refrigerant can accumulate within the compressor. Wait 12 hours before switching the device back on! Acting contrary might lead to compressor damage and a malfunctioning device.

No.	Designation
1	Air outlet with adjustable ventilation flaps
2	Transport handle
3	Wheels
4	Control panel
5	Air inlet with air filter
6	Condensate outlet with rubber stopper
7	Exhaust air hose connection
8	Hose connection with rubber stopper (<i>dehumidification mode</i>)
9	Remote control

Storage

Before storing the device, observe the following:

- Drain the remaining condensate from the device.
- Disconnect the device from the mains by removing the mains plug from the socket. When doing so, be sure to hold the plug, not the cable.

When the device is not being used, observe the following storage conditions:

- Only store the device in a room measuring more than 11 m².
- Store the appliance in a room without continuously operating open flames (for example an operating gas appliance) or other potential ignition sources (for example an operating electric heater, hot surfaces);
- Store the device in a dry location and protected from frost and heat.
- Store the device in an upright position where it is protected from dust and direct sunlight.
- If required, use a cover to protect the device from invasive dust.
- Place no further devices or objects on top of the device to prevent it from being damaged.
- Remove the batteries from the remote control.

Assembly and start-up

Scope of delivery

- 1 x Device
- 1 x Exhaust air hose
- 1 x Hose adapter
- 1 x Hose connector
- 1 x Condensation drain hose
- 1 x Window shade
- 1 x Fixing set for window shade
- 1 x Remote control (without batteries)
- 1 x Manual

Unpacking the device



Warning

There is a danger of suffocation for children due to packaging material! Keep packaging films and parts away from children. There is a risk of death due to suffocation.

1. Open the cardboard box and take the device out.
2. Completely remove the packaging.
3. Fully unwind the power cable. Make sure that the power cable is not damaged and that you do not damage it during unwinding.

Start-up

When positioning the device, observe the minimum distance from walls or other objects as described in the Technical data chapter.

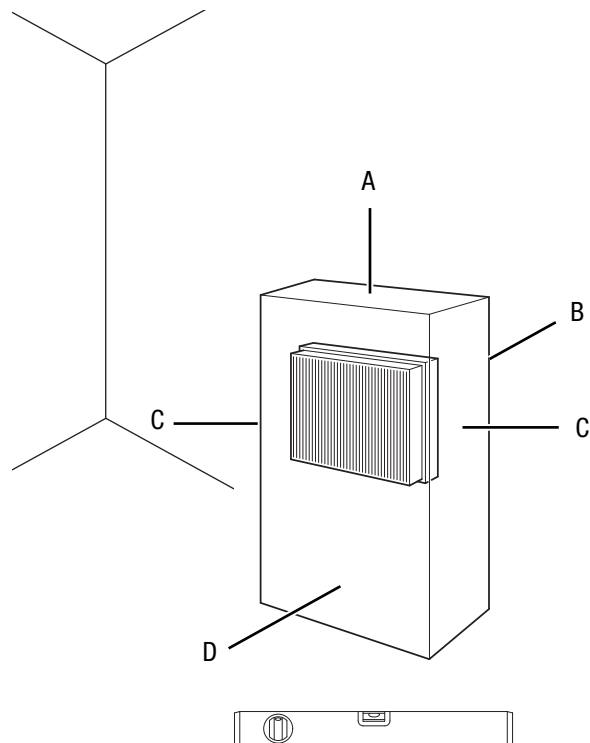

- Before restarting the device, check the condition of the power cable. If there are doubts as to the sound condition, contact the customer service.
- Only position the device in rooms where potentially leaking refrigerant cannot accumulate.
- Place the device in an upright and stable position on a horizontal and stable surface.
- Do not create tripping hazards when laying the power cable or other electric cables, especially when positioning the device in the middle of the room. Use cable bridges.
- Make sure that extension cables are completely unrolled.
- Keep air inlets and outlets as well as the exhaust air hose connection free.
- Make sure that no curtains or other objects interfere with the air flow.

Inserting batteries into the remote control

Notice

Do not use rechargeable batteries! Observe the Technical data for start-up.

Please proceed as follows to insert or exchange the batteries:

1. Remove the battery cover from the rear of the remote control.
2. Insert two batteries into the battery compartment according to the correct polarity.
3. Slide the battery cover back onto the remote control.

Inserting the air filter

Notice

Do not operate the device without an inserted air filter! Without the air filter, the inside of the device will be heavily contaminated. This could reduce the performance and result in damage to the device.

- Make sure that the air filters are installed before switching the device on.

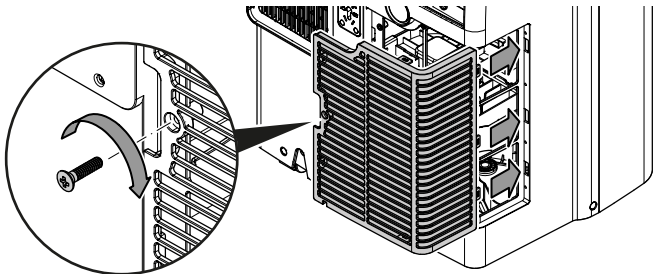
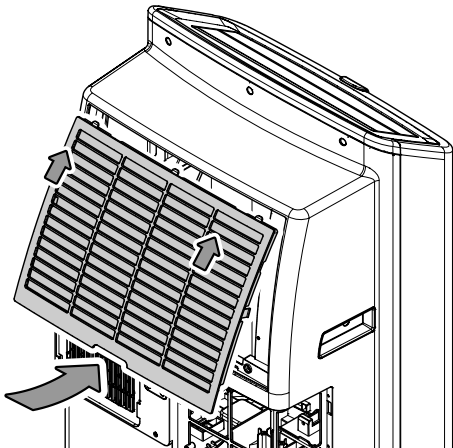

Connecting the exhaust air hose

1. Connect the hose adapter and the hose connector to one end of the exhaust air hose each.

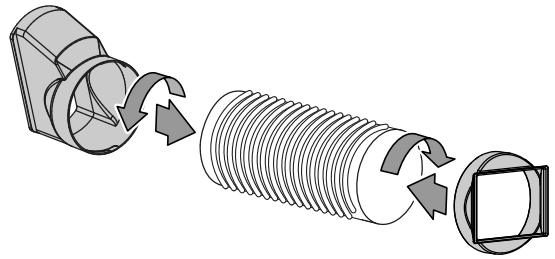

2. Connect the suitable end of the exhaust air hose to the exhaust air hose connection (6) located at the device.

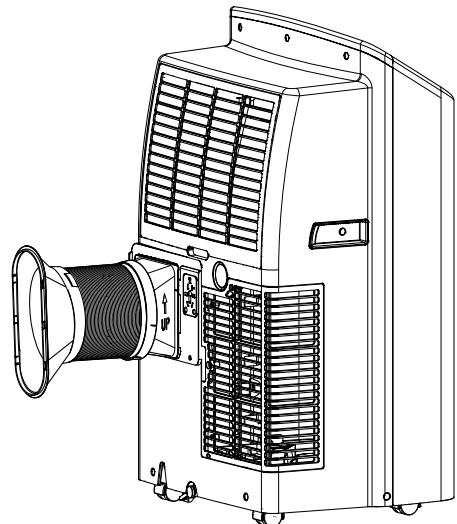
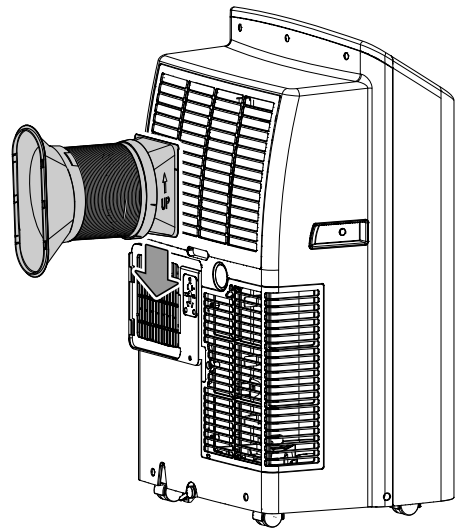

Discharging exhaust air

- The exhaust air coming from the device contains waste heat from the room to be cooled. For this reason it is recommended to discharge the exhaust air to the outside.
- The end of the exhaust air hose can be fed through the open window. If required, secure the open window with the corresponding means, so that the end of the exhaust air hose cannot shift.
- The end of the exhaust air hose can also be hooked into a tilted window.

For this purpose, we recommend using a window seal (optional).

- Install the exhaust air hose inclined with the air direction.
- The connected hose must not contain any source of ignition.

Example with exhaust air hose:

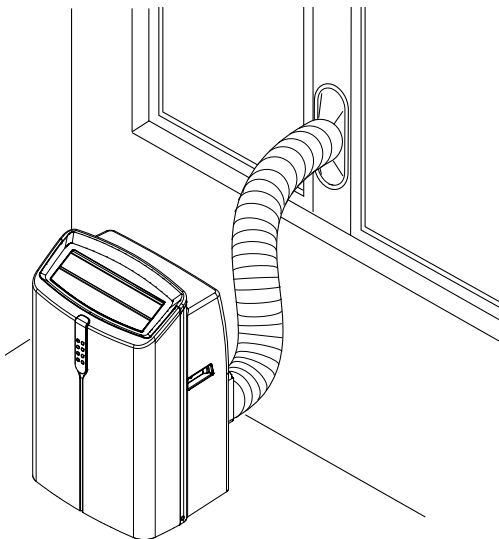

For installing the exhaust air hose please observe the following:

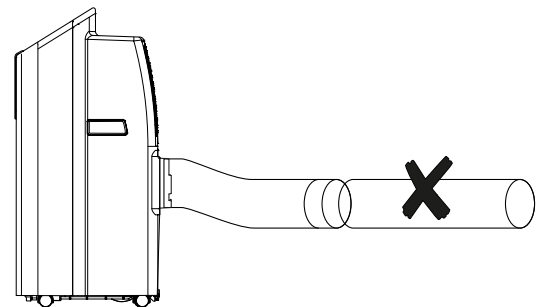
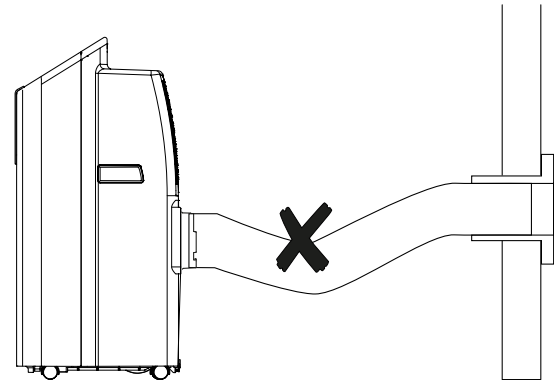
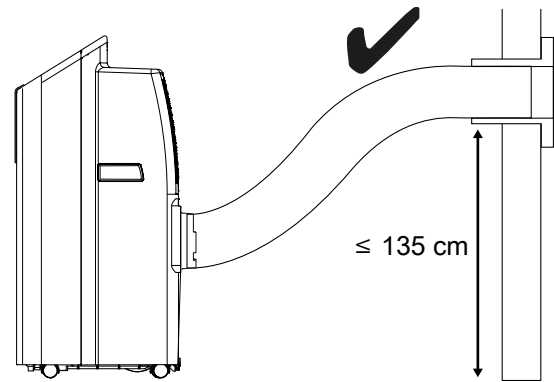
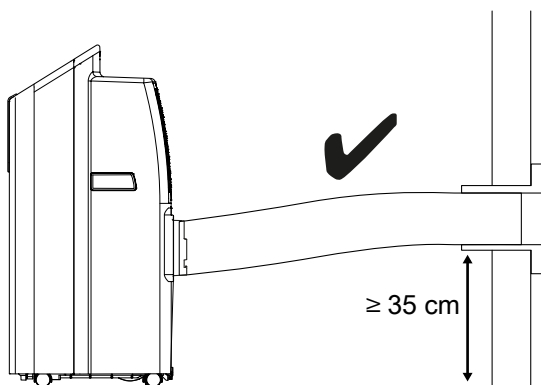

- Avoid kinks in the exhaust air hose. Kinks and bends would lead to an accumulation of emitted humid air causing the device to overheat and shut down.
- The dimensions of the exhaust air hose were especially made to fit the device. Do not replace or extend the hose. This could cause a malfunction of the device.

Connecting the power cable

- Connect the mains plug to a properly secured socket.

Operation

- Avoid open doors and windows.

Operating elements

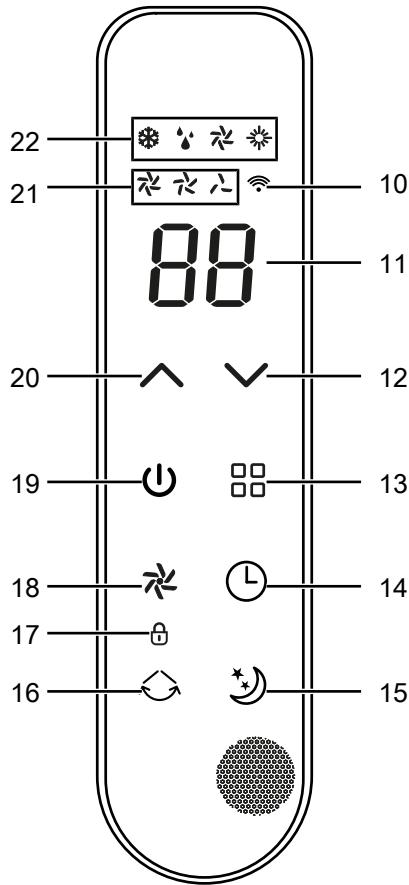

No.	Designation	Meaning
10	Wi-Fi LED	WLAN connection active
11	Segment display	Indication of the current room temperature in <i>dehumidification</i> and <i>ventilation</i> mode Indication of the target temperature in <i>cooling</i> and <i>heating</i> mode Indication of the set number of hours during timer programming Indication of the error code, see chapter Errors and faults
12	Down button	Reducing the target temperature for cooling and heating between 16 °C and 32 °C Reducing the number of hours for the timer in increments of 1 hour (1 h to 24 h)
13	Mode button	Selecting the operating mode: ❄ = <i>Cooling</i> 💧 = <i>Dehumidification</i> 🌀 = <i>Ventilation</i> ☀ = <i>heating</i>
14	Timer button	Switching the timer functions on or off
15	Night mode button	For switching <i>night mode</i> on or off
16	Swing / Lock button	For switching the swing function on or off Enabling or disabling key lock
17	Lock LED	Indicates that the key lock is activated
18	Speed button	Setting the fan speed
19	On / Off button	For switching the device on or off
20	Up button	Increasing the target temperature for cooling and heating between 16 °C and 32 °C Increasing the number of hours for the timer in increments of 1 hour (1 h to 24 h)
21	Fan speed LEDs	Fan speed indication: Stage 1 = low Stage 2 = high Stage 3 = maximum
22	Operating mode LEDs	Indicates the selected operating mode: ❄ <i>cooling</i> 💧 <i>dehumidification</i> 🌀 <i>ventilation</i> ☀ <i>heating</i>

Remote control

All settings of the device can also be made using the remote control included in the scope of delivery.

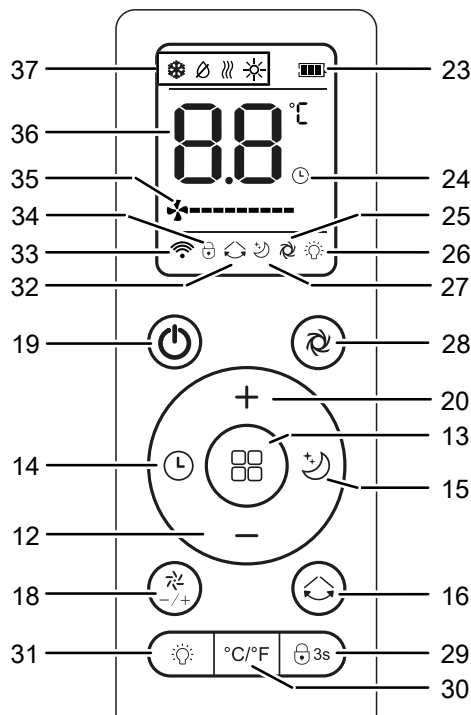

No.	Designation	Meaning
23	Battery indication	Battery charge level
24	Timer indication	Timer function is activated
25	Express indication	Express function is switched on
26	LED off indication	LEDs on the control panel are switched off
27	Night mode indication	Night mode is activated
28	Express button	For switching to <i>cooling</i> mode at 16 °C and activating the highest fan speed
20	UP button	Increasing the target temperature for cooling and heating between 16 °C and 32 °C Increasing the number of hours for the timer in increments of 1 hour (1 h to 24 h)
13	Mode button	Selecting the operating mode: * = <i>Cooling</i> ∅ = <i>Dehumidification</i> ≡ = <i>Ventilation</i> * = <i>heating</i>
15	Night mode button	For switching <i>night mode</i> on or off
16	Swing button	For switching the swing function on or off

No.	Designation	Meaning
29	Lock button	Enabling or disabling key lock
30	°C/°F button	Switching between °C and °F
31	LED off button	Switching the LEDs on the control panel on or off
12	Down button	Reducing the target temperature for cooling and heating between 16 °C and 32 °C Reducing the number of hours for the timer in increments of 1 hour (1 h to 24 h)
14	Timer button	Switching the timer functions on or off
19	On / Off button	For switching the device on or off
32	Swing indication	Swing function is switched on
33	WiFi indication	WLAN connection is active
34	Lock indication	Key lock is activated
35	Fan indication	Current fan speed
36	Segment display (remote control)	Indication of the current room temperature in <i>dehumidification</i> and <i>ventilation mode</i> Indication of the target temperature in <i>cooling</i> and <i>heating mode</i> Indication of the set number of hours during timer programming Indication of the error code, see chapter Errors and faults
37	Operating mode indication	Indicates the selected operating mode: * <i>cooling</i> ∅ <i>dehumidification</i> ≡ <i>ventilation</i> * <i>heating</i>



Info

An acoustic signal is emitted each time a setting is activated.

Switching the device on

1. Allow the device to rest for a time.
2. Once you have completely installed the device as described in the Start-up chapter, you can switch it on.
3. Press the *On / Off* button (19).
 - ⇒ The device starts in *ventilation mode*.
 - ⇒ The *Fan speed* LEDs (21) indicate the selected fan stage.
 - ⇒ The current room temperature is indicated on the segment display (11).
 - ⇒ The air outlet (1) opens automatically.
4. Select the desired operating mode.

The device switches off automatically when the condensation tray is full. *Ft* is displayed on the segment display (11).

Setting the operating mode

The device has the following operating modes:

- Cooling
- Dehumidification
- Ventilation
- Heating

Cooling

In *cooling* mode the room will be cooled down to the desired target temperature.

1. Press the *Mode* button (13) until the *Operating mode* LEDs (22) show *cooling*.
⇒ *Cooling* mode is selected.
2. Repeatedly press the *Up* (20) or *Down* (12) button to select the desired target temperature. The temperature can be adjusted in increments of 1 °C in a range between 16 °C and 32 °C.
⇒ The desired target temperature is indicated on the segment display (11).
3. Press the *Speed* button (18) to set the desired fan stage.
⇒ The *Fan speed* LED (21) for the desired fan stage will be illuminated.

Express function

To cool a room down as quickly as possible, the device is equipped with an express function.

1. Press the *Express* button (28).
⇒ *Cooling* mode is activated.
⇒ The target temperature is set to 16 °C.
⇒ The highest fan speed is activated.
2. Press the *Express* button (28) again to return to the previous setting.

Dehumidification

In *dehumidification* mode the humidity level in the room is reduced.



Info

During *dehumidification* mode, the exhaust air hose must be connected so that the condensate can escape from the room to be dehumidified.

1. Press the *Mode* button (13) until the *Operating mode* LEDs (22) show *dehumidification*.
⇒ *Dehumidification* mode is selected.
⇒ The current room temperature is indicated on the segment display (11).
⇒ The temperature and the fan speed (stage I) are preset in this operating mode and cannot be changed.



Info

If the device is operated in a very humid environment, the accumulating condensate must be discharged at regular intervals (see Condensate discharge).

Connecting the condensation drain hose

If you use the device for an extended period of time or you don't want to empty the tank all the time, you can connect a condensation drain hose to the hose connection.

- ✓ The device is switched off.
 - ✓ The device is disconnected from the mains.
1. Carefully transport or wheel the device to a suitable location for discharging the condensate (e.g. a drain) or position a suitable collection container under the condensate outlet.
 2. Remove the rubber stopper from the hose connection (8).

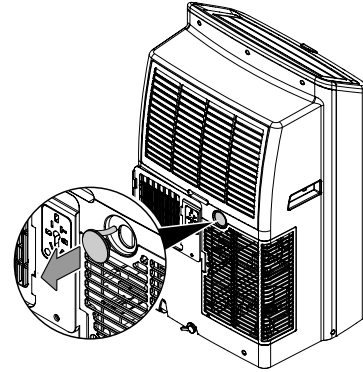

3. Connect the condensation drain hose to the hose connection (8).

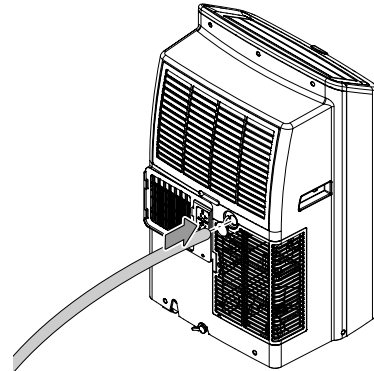

4. Guide the other hose end to a suitable drain or sufficiently dimensioned collection container. To ensure that the condensate can run off, the condensation drain hose must not be kinked, nor should it have to overcome an uphill incline towards the drain.

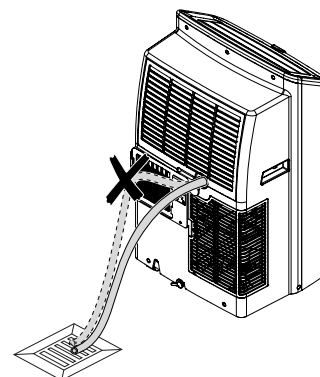

Ventilation



Info

Remove the exhaust air hose during *Ventilation*.

In *ventilation* mode the room air is circulated, it will neither be cooled nor dehumidified.

1. Press the *Mode* button (13) until the *Operating mode* LEDs (22) show *ventilation*.
 - ⇒ *Ventilation* mode is selected.
 - ⇒ The current room temperature is indicated on the segment display (11).
2. Press the *Speed* button (18) to set the desired fan speed.
 - ⇒ The LED for the selected fan speed (21) will be illuminated.

Heating

In *Heating* mode the room will be heated up to the desired target temperature.

1. Press the *Mode* button (13) until the *Operating mode* LEDs (22) show *heating*.
 - ⇒ *Heating* mode is selected.
2. Repeatedly press the *Up* (20) or *Down* (12) button to select the desired target temperature. The temperature can be adjusted in increments of 1 °C in a range between 16 °C and 32 °C and must be higher than the current room temperature.
 - ⇒ The desired target temperature is indicated on the segment display (11).
3. Press the *Speed* button (18) to set the desired fan stage.
 - ⇒ The *Fan speed* LED (21) for the desired fan stage will be illuminated.



Info

During *heating* mode, the exhaust air hose must be connected so that any condensate can be discharged.



Info

After switch-off, the fan keeps running for a brief period during which no settings can be made.

Setting the timer

The timer has two modes of operation:

- automatic switch-on upon expiry of a preset number of hours
- automatic switch-off upon expiry of a preset number of hours

The timer can be programmed in increments of 1 hour (1 h to 24 h).

The function can be set in all operating modes. It can be activated both during operation and in standby mode.

Notice

The device must not be left unattended in a freely accessible room with an activated timer.

Automatic switch-on

✓ The device is switched off.

1. Press the *Timer* button (14) until the *Timer* indication (24) appears.
 - ⇒ The number of hours flashes on the segment display (11) for approx. 4 seconds.
2. Use the *Up* button (20) and *Down* button (12) to set the desired number of hours until automatic switch-on.
 - ⇒ The number of hours until automatic switch-on will be indicated on the segment display (11) for approx. 4 seconds.
 - ⇒ The timer is now set to the desired number of hours.
 - ⇒ After the predefined time, the device switches on and starts in the last selected operating mode.
3. In order to delete the setting, select 00 hours.
 - ⇒ The *Timer* indication (24) disappears.

Notes regarding automatic switch-on:

- If the device is disconnected from the power supply, all settings for automatic switch-on are deleted.
- Manually switching the device on disables the automatic switch-on function.

Automatic switch-off

✓ The device is switched on.

1. Press the *Timer* button (14) until the *Timer* indication (24) appears.
 - ⇒ Use the *Up* button (20) and *Down* button (12) to set the desired number of hours until automatic switch-off.
 - ⇒ The number of hours until automatic switch-off will be indicated on the segment display (11) for approx. 4 seconds.
 - ⇒ The timer is now set to the desired number of hours.
 - ⇒ After the predefined time, the device switches itself off.
2. In order to delete the setting, select 00 hours.
 - ⇒ The *Timer* indication (24) disappears.

Notes regarding automatic switch-off:

- Pressing the *On/Off* button (19) deactivates the automatic switch-off function.
- Automatic switch-off can also be enabled or disabled in standby mode.

Automatic defrost

At low ambient temperatures, ice may form at the evaporator. The device will then carry out an automatic defrost.

The compressor switches off and the fan keeps running until defrosting is completed. The duration of the defrost process can vary.

Do not switch the device off during automatic defrost. Do not remove the mains plug from the mains socket.

Night mode

Night mode can be activated in *cooling* and *heating* mode.

Night mode has the following settings in *cooling* mode:

- After 1 hour the preset temperature is increased by 1 °C. After another hour the preset temperature will again be increased by 1 °C. Then the temperature is kept constant for 12 hours before the device switches off automatically.
- The fan speed can be changed. This will deactivate night mode.

Night mode has the following settings in *heating* mode:

- After 1 hour the preset temperature is reduced by 1 °C. After another hour the preset temperature will again be reduced by 1 °C. Then the temperature is kept constant for 10 hours and the LED indications are switched off before the device sets the original temperature automatically.
- The fan speed is preset to the lowest stage and cannot be adjusted.

To activate night mode, please proceed as follows:

1. Select *Cooling* or *Heating* mode.
2. Set the lowest fan speed.
3. Press the *Night mode* button (15).
⇒ The *Night mode* indication (27) is illuminated.
4. In order to switch off night mode, press the *Night mode* button (15) once again.
⇒ The *Night mode* indication (27) disappears.
⇒ The selected operating mode remains active.

Swing function

The swing function can be switched on in any operating mode if required.

By means of the swing function, the air outlet (1) is moved automatically and thus ensures continuous air circulation.

1. Press the *Swing* button (16).
⇒ The ventilation flaps move up and down continuously.
2. Press the *Swing* button (16) again to stop the ventilation flaps in a certain position and to switch off the swing function.

Key lock

The key lock prevents accidental or unauthorised access to the operating elements.

1. Press and hold the *Swing* button (16) for three seconds or press the *Lock* button (29) on the remote control.
⇒ The operating elements are locked.
2. Press and hold the *Swing* button (16) for three seconds once again or press the *Lock* button (29) on the remote control.
⇒ The key lock is deactivated and the operating elements are active again.

Changing the unit °C / °F (remote control only)

The temperature in the segment display (11) can be indicated in °C or °F.

Please proceed as follows to change the temperature unit:

1. Press the °C/°F button (30) on the remote control.
⇒ The displayed temperature is converted to the other unit.

Operation with WiFi

Trotec Assistant App



All settings can also be made via the Trotec Assistant App. The settings of the timer functions that are operated via the app are not additionally displayed on the control panel of the device.

Install the Trotec Assistant App on the terminal device you want to use in combination with the device.



Info

Some of the app's functions require access to your location and an active Internet connection.

The app is available for download in the Google Play Store as well as in Apple's app store and via the following link:



<https://hub.trotec.com/?id=45093>

WiFi connection

Proceed as follows to establish a WiFi connection:

- ✓ The device is in standby mode.
- 1. Download the Trotec Assistant App and open it on a smartphone.
- 2. Select *Add Device* by pressing the + sign in the top right corner.
- 3. Select *Large household appliances* and *Air conditioning (Wi-Fi)* among them.
- 4. Press the *Speed* button (18) on the control panel of the device for approx. 5 seconds.
 - ⇒ The *Wi-Fi* LED (10) flashes.
 - ⇒ The device is in *Quick Connect* mode.
- 5. Follow the instructions of the app on the smartphone.
 - ⇒ Once the *Wi-Fi* LED (10) is permanently illuminated, the connection has been established.

Info

If the WLAN connection is interrupted, the device may not automatically reconnect to the network. If this is the case, re-establish the connection with the *Speed* button (18).

Shutdown



Warning of electrical voltage

Do not touch the mains plug with wet or damp hands.

- Switch the device to standby mode by pressing the *On / Off* button (19).
- Disconnect the device from the mains by removing the mains plug from the socket. When doing so, be sure to hold the plug, not the cable.
- Empty the condensation tray if necessary.
- If necessary, remove the condensation drain hose and any residual fluid from it.
- If required, clean the device according to the "Maintenance" chapter.
- Store the device according to the Transport and storage chapter.

Errors and faults

The device has been checked for proper functioning several times during production. If malfunctions occur nonetheless, check the device according to the following list.

Notice

Wait for at least 3 minutes after maintenance and repair work. Only then switch the device back on.

The device does not start:

- Check the power connection.
- Check the power cable and mains plug for damage. If you notice damages, do not try to take the device back into operation.
If the supply cord is damaged, it must be replaced by the manufacturer, its service agent or similarly qualified persons in order to avoid a hazard.
- Check the on-site fusing.
- Observe the operating temperature according to the chapter Technical annex.
- The condensation tank may be full. Empty the condensation tank, if need be. The error code *Ft* must not be indicated on the segment display.
- If the device is not starting, have the electricians checked by a specialist company or by the manufacturer.

The device works with reduced or no cooling capacity:

- Check whether *cooling* mode is selected.
- Check the position of the flap at the air outlet (1). The flap at the air outlet (1) must be opened as far as possible.
- Check the air filter(s) for dirt. If necessary, clean or replace the air filter(s).
- Check the minimum distance to walls or other objects. Position the device a little more in the room's centre if required.
- Check the temperature setting at the device. Reduce the set temperature if it is higher than the room temperature.

The device is loud or vibrates:

- Check whether the device is set up in a stable and upright position.

Condensate is leaking:

- Check the device for leaks.

The compressor does not start:

- Check whether the overheating protection of the compressor has tripped. Disconnect the device from the mains and let it cool down for approx. 10 minutes before reconnecting it.
- The compressor may start up with a delay of 3 minutes, as it is provided with an internal protection against direct restart.

The device gets very warm, is loud or is losing power:

- Check the air inlet and air filter for dirt. Remove external dirt.
- From the outside, check the device for dirt (see chapter Maintenance). If the inside of the device is dirty, have it cleaned by a specialist company for cooling and air-conditioning or by the manufacturer.

The device does not respond to the infrared remote control:

- Check whether the distance between remote control and device is too large and reduce it if necessary.
- Make sure there are no obstacles, such as furniture or walls, between the device and the remote control. Ensure visual contact between device and remote control.

The device still does not operate correctly after these checks:

Please contact the customer service. If necessary, bring the device to a specialist company for cooling and air-conditioning or to the manufacturer for repair.

Error codes

The following error messages can be displayed on the segment display (11):

Error code	Cause	Remedy
E0/00	Communication error between main circuit board and display circuit board	Check the control panel frame for damage.
E1	Fault at temperature sensor	Disconnect the device briefly from the mains. Should the error still be displayed, please contact the customer service.
E2	Error at the sensor for the coil	Disconnect the device briefly from the mains. Should the error still be displayed, please contact the customer service.
Ft	Condensation tray full	The condensation tray is full. Drain the condensate, see chapter Condensate discharge (Manual draining). Should the error still be displayed, please contact the customer service.

Maintenance

Maintenance intervals

Maintenance and care interval	before every start-up	as needed	at least every 2 weeks	at least every 4 weeks	at least every 6 months	at least annually
Check air inlets and outlets for dirt and foreign objects and clean if necessary	X			X		
Clean the exterior		X				X
Visually check the inside of the device for dirt		X				X
Check the air filter for dirt and foreign objects and clean or replace if necessary	X		X			
Replace the air filter					X	
Check for damage	X					
Check the attachment screws		X				X
Test run						X
Empty the condensation tray and drain hose		X				

Maintenance and care log

Device type:

Device number:

Maintenance and care interval	1	2	3	4	5	6	7	8	9	10	11	12	13	14	15	16
Check air inlets and outlets for dirt and foreign objects and clean if necessary																
Check air inlets and outlets for dirt and foreign objects and clean if necessary																
Clean the exterior																
Visually check the inside of the device for dirt																
Replace the air filter																
Check the attachment screws																
Test run																
Empty the condensation tray and drain hose																
Comments																

1. Date: Signature:	2. Date: Signature:	3. Date: Signature:	4. Date: Signature:
5. Date: Signature:	6. Date: Signature:	7. Date: Signature:	8. Date: Signature:
9. Date: Signature:	10. Date: Signature:	11. Date: Signature:	12. Date: Signature:
13. Date: Signature:	14. Date: Signature:	15. Date: Signature:	16. Date: Signature:

Activities required before starting maintenance



Warning of electrical voltage

Do not touch the mains plug with wet or damp hands.

- Switch the device off.
- Disconnect the device from the mains by removing the mains plug from the socket. When doing so, be sure to hold the plug, not the cable.



Warning of electrical voltage

Tasks which require the device to be opened must only be carried out by authorised specialist companies or by the manufacturer.

Refrigerant circuit



Danger

Natural refrigerant propane (R290)!

H220 – Extremely flammable gas.

H280 – Contains gas under pressure; may explode if heated.

P210 – Keep away from heat, sparks, open flames and other ignition sources. No smoking.

P377 – Leaking gas fire: Do not extinguish, unless leak can be stopped safely.

P410+P403 – Protect from sunlight. Store in a well-ventilated place.

- The entire refrigerant circuit is a maintenance-free, hermetically sealed system and may only be maintained or repaired by specialist companies for cooling and air-conditioning or by the manufacturer.

Safety signs and labels on the device

Check the safety signs and labels attached to the device at regular intervals. Replace illegible safety signs!

Cleaning the housing

Clean the housing with a soft, damp and lint-free cloth. Make sure that no moisture enters the housing. Protect electrical components from moisture. Do not use any aggressive cleaning agents such as cleaning sprays, solvents, alcohol-based or abrasive cleaners to dampen the cloth.

Visual inspection of the inside of the device for dirt

1. Remove the air filter.
2. Use a torch to illuminate the openings of the device.
3. Check the inside of the device for dirt.
4. If you see a thick layer of dust, have the inside of the device cleaned by a specialist company for cooling and air-conditioning or by the manufacturer.
5. Put the air filter back in.

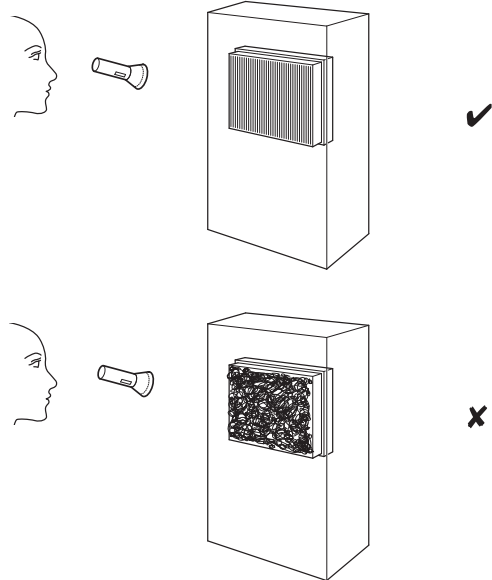

Cleaning the air filter

The air filters have to be cleaned as soon as they are dirty. This is brought to light e.g. by a reduced capacity (see chapter Errors and faults).



Warning

Ensure that the air filters are neither worn nor damaged. The corners and edges of the air filters must not be deformed or rounded. Before reinserting the air filters, make sure that they are undamaged and dry!

1. Remove the air filters from the device.

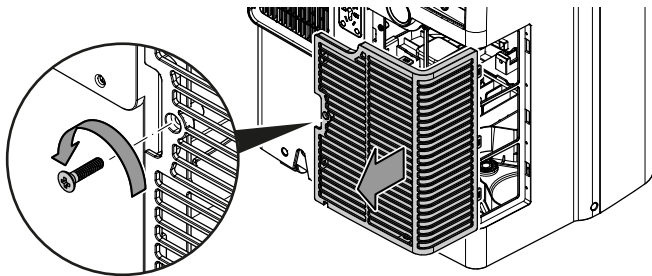
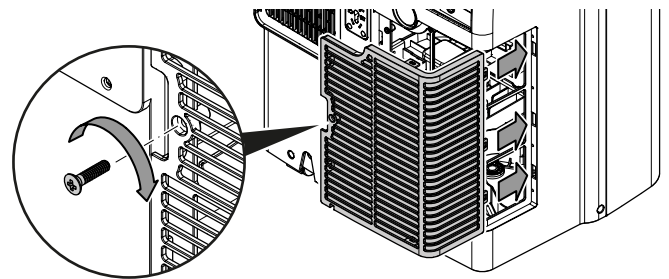
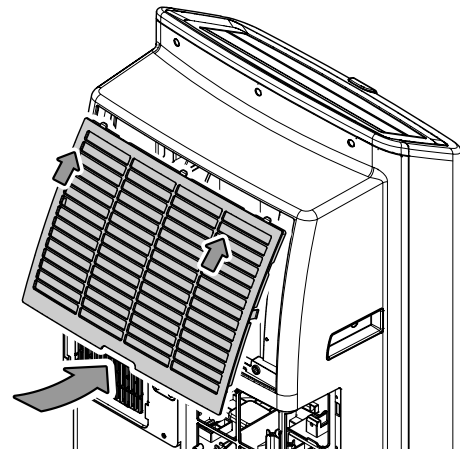
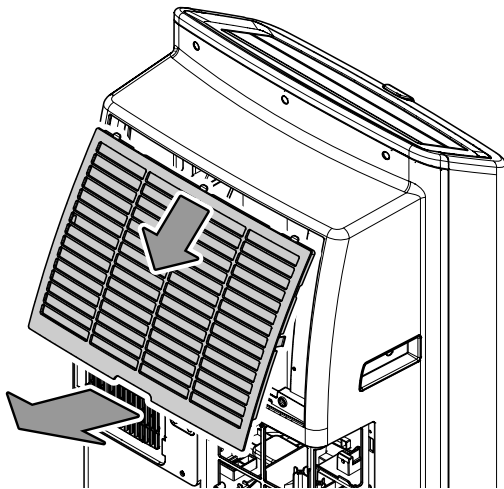

2. Clean the filters using a slightly damp, soft, lint-free cloth. If the filters are heavily contaminated, clean them with warm water mixed with a neutral cleaning agent.

3. Allow the filters to dry completely. Do not put any wet filters into the device!
4. Reinsert the air filters into the device.

Condensate discharge (manual draining)

In *cooling*, *heating* and *dehumidification* mode condensate is formed, which is mostly discharged via the exhaust air.

The remaining condensate is collected in a condensation tray within the housing. The condensate must be drained regularly.

1. Check whether there is a drain at the installation site or provide a suitable collection container under the condensate outlet.

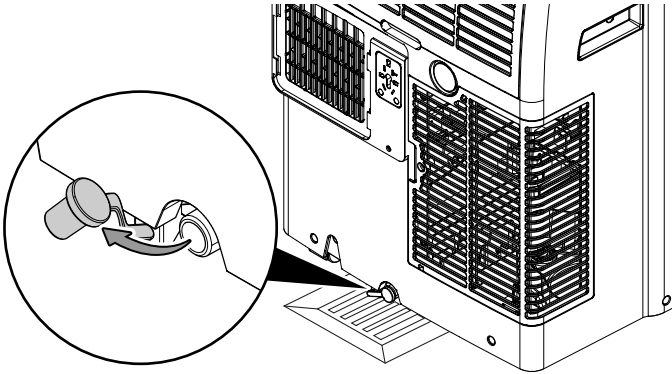

2. Drain the condensate.
3. Reattach the rubber stopper to the condensate outlet. Ensure the tight fit of the rubber stopper, for otherwise there might be uncontrolled water leakage.

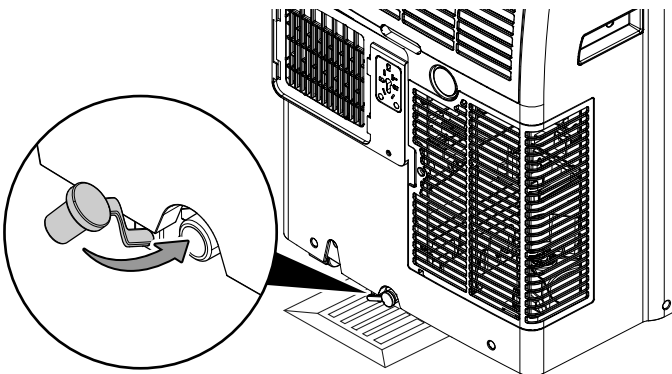

⇒ The *Ft* error code on the segment display (11) will no longer be displayed once the condensate has been drained.

Activities required after maintenance

If you want to continue using the device:

- Leave the device to rest for at least 12 hours, so the refrigerant can accumulate within the compressor. Wait 12 hours before switching the device back on! Acting contrary might lead to compressor damage and a malfunctioning device.
- Reconnect the device to the mains.

If you do not intend to use the device for a considerable time:

- Store the device according to the Transport and storage chapter.

Technical annex
Technical data

Model	PAC 4100 SH
Cooling capacity	4.1 kW
Heating capacity	3.2 kW
Dehumidification performance	1.5 l/h
Operating temperature	3 °C to 35 °C
Temperature setting range	16 °C to 32 °C
Max. air volume flow	460 m ³ /h
Mains connection	220 V – 240 V / 50 Hz
Nominal current	7.0 A
Fusing 	AC 250 V, 3.15 A, type T
Type of protection	IPX1
Power consumption (cooling)	1550 W
Power consumption (heating)	1250 W
Sound pressure level at a distance of 1 m	54 dB(A)
Refrigerant	R290
Amount of refrigerant	190 g
GWP factor	3
CO ₂ equivalent	0.00057 t
Suction side pressure	1.5 MPa
Discharge side pressure	3.0 MPa
Max. permissible pressure	3.0 MPa
Dimensions (length x width x height)	350 x 440 x 740 mm
Minimum distance to walls and other objects:	top (A): 50 cm rear (B): 50 cm sides (C): 50 cm front (D): 50 cm
Weight	29.5 kg
Remote control batteries	Type LR03 / AAA – 1.5 V (2 pcs.)

Circuit diagram

Note: The functions shown with dotted lines are optional or not available on this device.

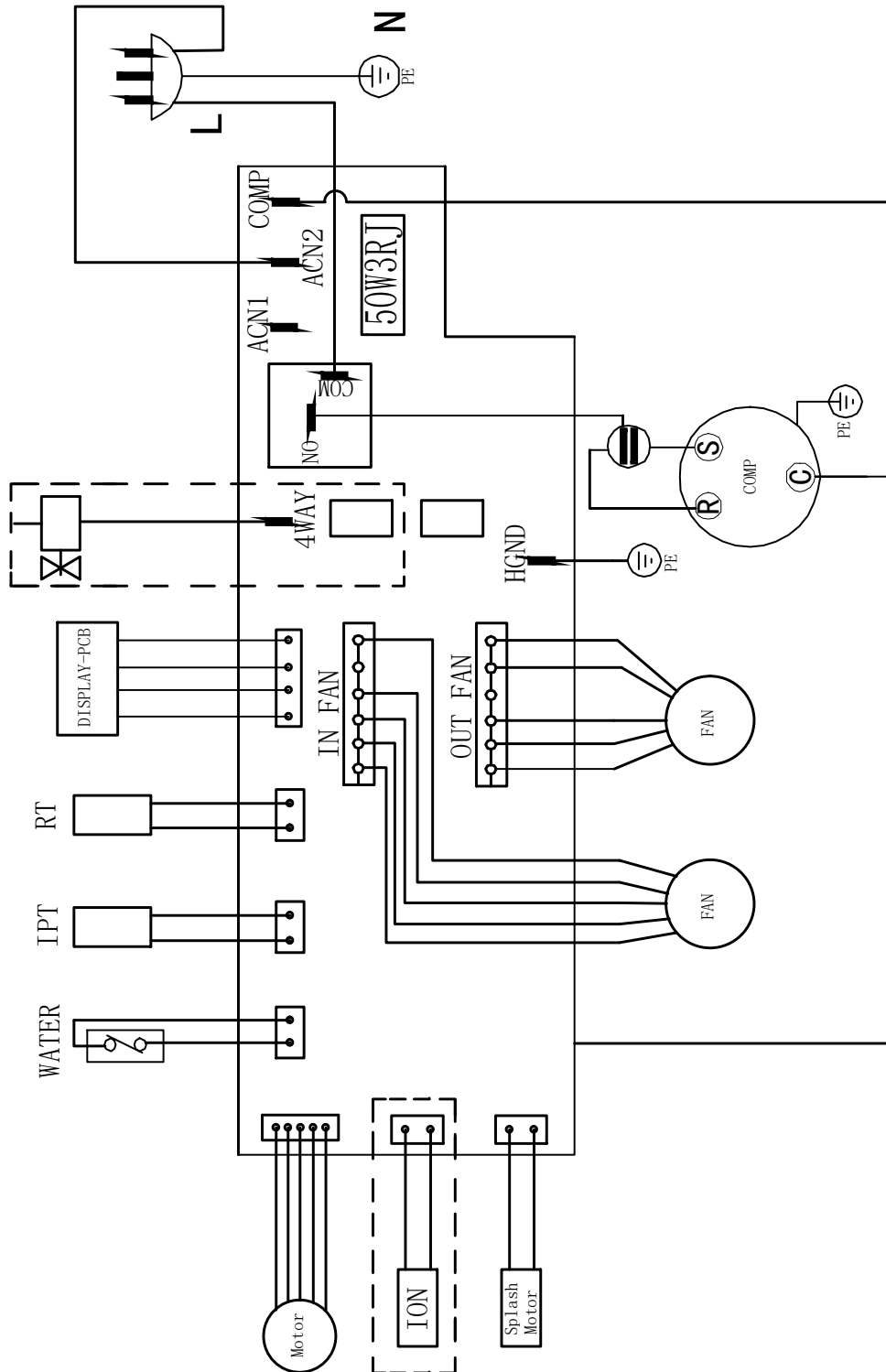

Overview and list of spare parts

Note: The position numbers of the spare parts differ from those describing the positions of the components mentioned in these instructions.

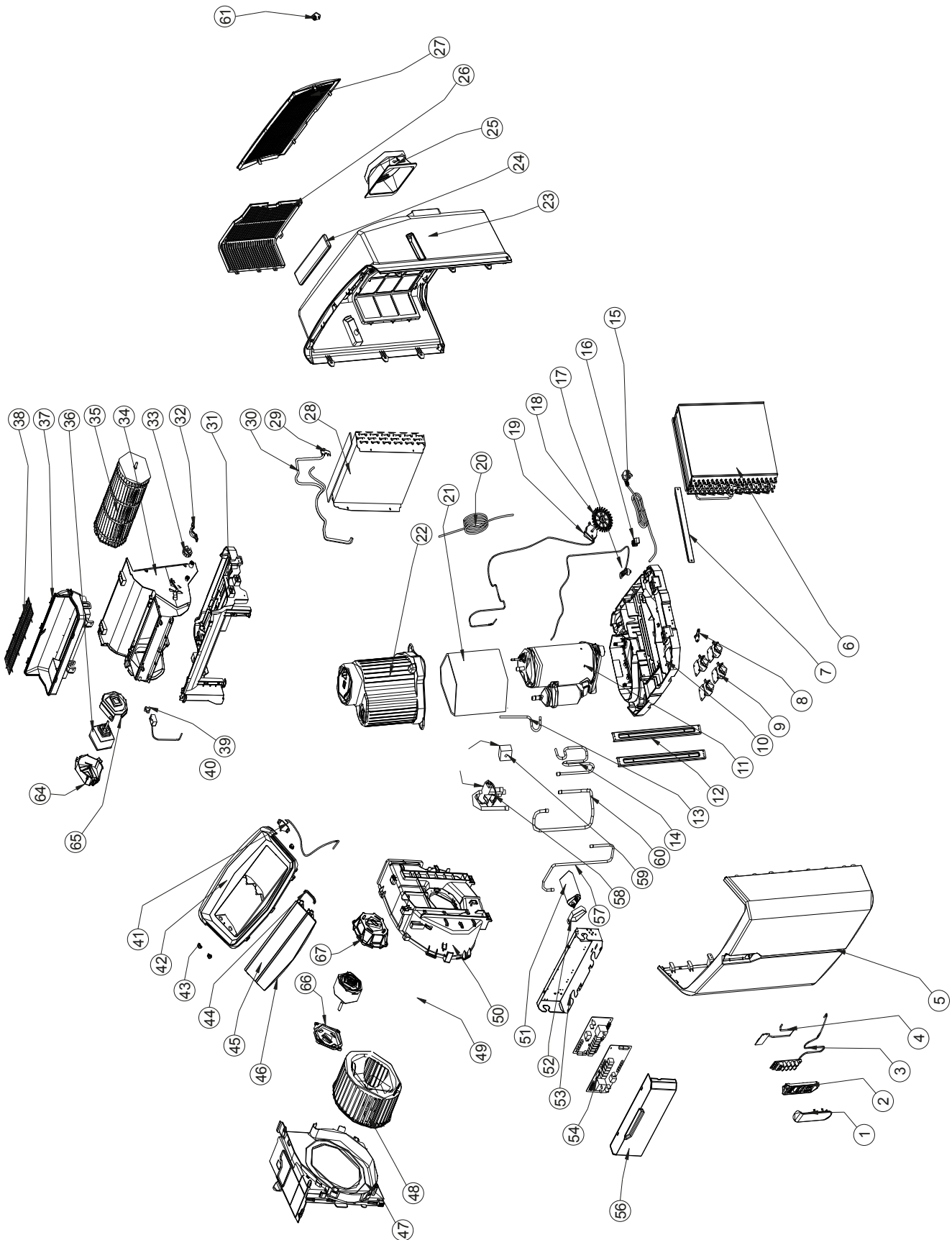

No.	Spare part	Quantity	No.	Spare part	Quantity	No.	Spare part	Quantity
1	DISPLAY BOX COVER	1	22	COMPRESSOR SILENCING COVER	1	45	UPPER HORIZONTAL SWING BLADE	1
2	CONTROL BOX	1	23	BACK COVER	1	46	LOWER HORIZONTAL SWING BLADE	1
3	DISPLAY BOARD	1	24	REMOTE CONTROL	1	47	LOWER AIR DUCT	1
4	WIFI	1	25	HOSE INLET	1	48	CENTRIFUGAL WIND TURBINE	1
5	FRONT SHELL	1	26	CON FILTER FRAME	1	49	LOWER MOTOR	1
6	CONDENSER ASS'Y	1	27	EVA FILTER FRAME	1	50	UNDERAIR DUCT COVER	1
7	COMPRESSOR ANTI-COLLISION BAR	1	28	EVAPORATOR	1	51	COMPRESSOR CAPACITOR	1
8	LOWER WATER STOP PLUG	1	29	BRACKET	1	52	CAPACITOR CLAMP	1
9	CASTER	4	30	ROOM TEMPERATURE SENSOR	1	53	ELECTRICAL CONTROL BOX	1
10	BASE	1	31	UPPER DUCT BASE	1	54	MAIN BOARD	1
11	COMPRESSOR	1	32	BEARING PRESSURE PLATE	1	56	ELECTRICAL CONTROL BOX	1
12	SUPPORT BAR	2	33	RUBBER BEARINGS	1	57	DELIVERY TUBE	1
13	E CONNECTION	1	34	UPPER DUCT	1	58	FOUR-WAY VALVE	1
14	C TAKES OVER		35	CROSS-FLOW FAN	1	59	COIL FOR FOUR-WAY VALVE	1
15	POWER CORD	1	36	UPPER MOTOR	1	60	SUCTION TUBE	1
16	LINE CORD	1	37	UPPER AIR VENT	1	61	UPPER RUBBER PLUG	1
17	FLOATER SWITCH	1	38	BARBED WIRE	1	64	MOTOR BACK COVER	1
18	WATER WHEEL	1	41	STEP MOTOR	1	65	MOTOR FRONT COVER	1
19	WATER MOTOR	1	42	TOP COVER	1	66	LOWER MOTOR FRONT COVER	1
20	CAPILLARY	1	43	AXLE SLEEVE	1	67	LOWER MOTOR COVER	1
21	COMPRESSOR SILENCING COTTON	1	44	LATERAL BLADE CONNECTING ROD	1	68	HOSE OUTLET	1

Disposal

Always dispose of packing materials in an environmentally friendly manner and in accordance with the applicable local disposal regulations.



The icon with the crossed-out wheeled bin indicates that this device and any associated components (e.g. remote controls) must not be disposed of with household waste at the end of their life, in accordance with the Waste Electrical and Electronic Equipment Directive (2012/19/EU) and national laws.

You will find collection points for free return of waste electrical and electronic equipment in your vicinity. The addresses can be obtained from your municipality or local administration. You can also find out about other return options that apply for many EU countries on the website <https://hub.trotec.com/?id=45090>. Otherwise, please contact an official recycling centre for electronic and electrical equipment authorised for your country.

The separate collection of waste electrical and electronic equipment aims to enable the re-use, recycling and other forms of recovery of waste equipment as well as to prevent negative effects for the environment and human health caused by the disposal of hazardous substances potentially contained in the equipment.



This icon with the crossed-out wheeled bin indicates that batteries or accumulators must not be disposed of with household waste at the end of their life. If the device contains batteries or accumulators that contain mercury, cadmium or lead, the respective chemical symbol (Hg, Cd or Pb) is shown below the icon of the crossed-out wheeled bin. To prevent environmental pollution, do not carelessly leave batteries or electrical and electronic equipment containing batteries in public areas. In the European Union, batteries and accumulators must be returned to a designated collection point in accordance with REGULATION (EU) 2023/1542 OF THE EUROPEAN PARLIAMENT AND OF THE COUNCIL of 12 July 2023 concerning batteries and waste batteries. Remove batteries/accumulators and dispose of them separately according to the relevant legal requirements.

Have the refrigerant (propane) disposed of appropriately and according to the national regulations by a company with the relevant certification (European Waste Catalogue 160504).

Only for United Kingdom

According to Waste Electrical and Electronic Equipment Regulations 2013 (SI 2013/3113) (as amended) and the Waste Batteries and Accumulators Regulations 2009 (SI 2009/890) (as amended), devices that are no longer usable must be collected separately and disposed of in an environmentally friendly manner.

Simplified EU Declaration of Conformity

Hereby, Trotec GmbH declares that the radio equipment type (PAC 4100 SH – Wifi module) is in compliance with Directive 2014/53/EU. The full text of the EU declaration of conformity is available at the following internet address:

<https://hub.trotec.com/?id=47713>

Trotec GmbH

Grebener Str. 7
52525 Heinsberg
Germany

☎ +49 2452 962-0

☎ +49 2452 962-200

✉ online@trotec.com

www.trotec.com