

**PT 5300 SP**

**EN**

**ORIGINAL INSTRUCTIONS**  
SPOT COOLING AIR  
CONDITIONING UNIT



 **TROTEC**

**Table of contents**

Notes regarding the instructions ..... 2

Safety ..... 2

Information about the device ..... 6

Transport and storage ..... 7

Assembly and start-up ..... 7

Operation ..... 10

Errors and faults ..... 13

Maintenance ..... 15

Technical annex ..... 17

Disposal ..... 21

Declaration of conformity ..... 21

**Notes regarding the instructions**

**Symbols**



**Danger**

This symbol indicates dangers to the life and health of persons due to flammable refrigerants.



**Warning of electrical voltage**

This symbol indicates dangers to the life and health of persons due to electrical voltage.



**Warning**

This signal word indicates a hazard with an average risk level which, if not avoided, can result in serious injury or death.



**Caution**

This signal word indicates a hazard with a low risk level which, if not avoided, can result in minor or moderate injury.

**Note**

This signal word indicates important information (e.g. material damage), but does not indicate hazards.



**Info**

Information marked with this symbol helps you to carry out your tasks quickly and safely.



**Follow the manual**

Information marked with this symbol indicates that the instructions must be observed.

You can download the current version of these instructions via the following link:

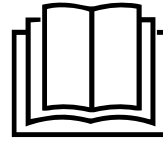

PT 5300 SP



<https://hub.trotec.com/?id=46129>

**Safety**

**Read this manual carefully before starting or using the device. Always store the manual in the immediate vicinity of the device or its site of use.**



**Warning**

**Read all safety warnings and all instructions.**

Failure to follow the warnings and instructions may result in electric shock, fire and/or serious injury.

**Save all warnings and instructions for future reference.**

This appliance can be used by children aged from 8 years and above and persons with reduced physical, sensory or mental capabilities or lack of experience and knowledge if they have been given supervision or instruction concerning use of the appliance in a safe way and understand the hazards involved.

Children shall not play with the appliance. Cleaning and user maintenance shall not be made by children without supervision.

- Do not use the device in potentially explosive rooms or areas and do not install it there.
- Do not use the device in aggressive atmosphere.
- Only put up the device in an upright, stable position on firm ground.
- Let the device dry out after a wet clean. Do not operate it when wet.
- Do not use the device with wet or damp hands.
- Do not expose the device to directly squirting water.
- Never insert any objects or limbs into the device.
- Do not cover the device during operation.
- Do not sit on the device.
- This appliance is not a toy. Keep away from children and animals.
- Check accessories and connection parts for possible damage prior to every use of the device. Do not use any defective devices or device parts.

- Ensure that all electric cables outside of the device are protected from damage (e.g. caused by animals). Never use the device if electric cables or the power connection are damaged!
- The mains connection must correspond to the specifications in the Technical annex.
- Insert the mains plug into a properly fused mains socket.
- Observe the technical data when selecting extensions to the power cable. Completely unroll the extension cable. Avoid electrical overload.
- Before carrying out maintenance, care or repair work on the device, remove the mains plug from the mains socket. Hold onto the mains plug while doing so.
- Switch the device off and disconnect the power cable from the mains socket when the device is not in use.
- Do not under any circumstances use the device if you detect damages on the mains plug or power cable. If the power cable is damaged, it must be replaced by the manufacturer, its service agent or similarly qualified persons in order to avoid a hazard. Defective power cables pose a serious health risk!
- When positioning the device, observe the minimum distances from walls and other objects as well as the storage and operating conditions specified in the Technical annex.
- Make sure that the air inlet and outlet are not obstructed.
- Do not remove any safety signs, stickers or labels from the device. Keep all safety signs, stickers and labels in legible condition.
- Make sure that the suction side is kept free of dirt and loose objects.
- Discharge the collected condensate before transport and storage. Do not drink it. Health hazard!
- Only transport the device in an upright position.



### **Safety warnings for devices containing flammable refrigerants**

- Only position the device in rooms where potentially leaking refrigerant cannot accumulate. Unventilated rooms, in which the device is installed, operated or stored, must be built in a way to ensure that potentially leaking refrigerant cannot accumulate. This serves to avoid fire or explosion hazards resulting from an ignition of the refrigerant by an electric furnace, cooking stove or another ignition source.
- Only position the device in rooms where there is no source of ignition (e.g. open flames, an active gas appliance or an electric heater).
- Please note that the refrigerant is odourless.
- Only install the device in compliance with the national installation regulations.
- Please observe the local regulations.
- Observe the national gas regulations.
- Only install, operate and store the device PT 5300 SP in a room measuring more than 15 m<sup>2</sup>.
- Store the device in a way that no mechanical damage can occur.
- Please note that the connected pipelines must not contain any sources of ignition.
- R1234yf is a refrigerant that complies with European environmental regulations. No part of the cooling circuit may be perforated.
- Observe the maximum refrigerant capacity in the technical data.
- Do not drill through or burn.
- Do not use any means other than those recommended by the manufacturer for accelerating the defrosting process.
- Every person working with or at the refrigerant circuit must be able to provide a certificate of qualification issued by a body accredited by the industry, demonstrating their competence in the safe use of refrigerants based on a procedure well-known in the industry.
- Service work may only be carried out in accordance with the manufacturer's specifications. If maintenance and repair work require the support of additional persons, the person trained in handling flammable refrigerants shall continuously supervise the work carried out.
- The entire refrigerant circuit is a maintenance-free, hermetically sealed system and may only be maintained or repaired by specialist companies for cooling and air-conditioning or by Trotec.

**Intended use**

Only use the device for cooling, ventilating and dehumidifying indoor air whilst adhering to the technical data.

The device is only suitable for commercial use.

The device can ideally be used for cooling server rooms, production departments and workplaces. The device has been designed to provide a quick installation and start-up process. The mobile device can be flexibly used due to the robust wheels with brakes.

**Foreseeable misuse**

- Do not place the device on wet or flooded ground.
- Do not place any objects, e.g. clothing, on the device.
- Do not use the device out of doors.
- Do not use the device in wet rooms (e.g. bathrooms or laundry rooms).
- Never immerse the device in water.
- Do not make any unauthorised modifications, alterations or structural changes to the device.
- Any use other than the intended use is regarded as a reasonably foreseeable misuse.

**Personnel qualifications**

People who use this device must:

- be aware of the dangers that occur when working with electric devices in damp areas.
- have read and understood the instructions, especially the Safety chapter.

Maintenance tasks which require the housing to be opened must only be carried out by specialist companies for cooling and air-conditioning or by Trotec.

**Electrically skilled person**

Electrically skilled personnel must be able to read and understand electric circuit diagrams, to put electrical systems into service and to maintain them, to wire control cabinets, to ensure the functionality of electrical components and to identify possible hazards from electrical and electronic systems.

**Safety signs and labels on the device**

**Note**

Do not remove any safety signs, stickers or labels from the device. Keep all safety signs, stickers and labels in legible condition.



The following safety signs and labels are attached to the device:

**WARNING • WARNUNG • ATTENTION**

**DE** Das Gerät muss in einem Raum mit einer Grundfläche größer als 15 m<sup>2</sup> aufgestellt, betrieben und gelagert werden.

**EN** Appliance shall be installed, operated and stored in a room with floor area larger than 15 m<sup>2</sup>.

**FR** L'appareil doit être installé, utilisé et entreposé dans une pièce avec une surface supérieure à 15 m<sup>2</sup>.

**Follow the manual**

This symbol indicates that the instructions must be observed.



**Follow the repair manual**

Disposal, maintenance and repair work of the refrigerant circuit may only be carried out in accordance with the manufacturer's specifications and by persons having a certificate of qualification. A corresponding repair manual is available from the manufacturer upon request.

The following labels are attached to the device in German and English.



**Warnings**

Make sure that no objects fall into the hot air inlet or the cooling air duct. Any foreign object will cause damage to the fan blades or potential blockage of the air current and is not covered by guarantee.



**Warnings**

Do not reach into the flexible air duct when adjusting the air angle for cold air. Adjust the angle by moving the plastic cover.



### Important

#### Regularly check the filter for dirt!

Excessive dust and dirt on the filter will affect the air supply and cause the heat exchanger to ice up. This leads to a drastic reduction of the cooling capacity.



### Attention

There are combustible gases inside the device. It is prohibited to disassemble or repair the device by non-qualified personnel!



### Warnings

Switch off the device when the **condensation tank full** indication is displayed. Remove the condensation tank and empty it. Make sure that the condensation tank is inserted correctly before switching the device back on.

### Residual risks



#### Danger

#### Refrigerant 2,3,3,3-Tetrafluoropropene (R1234yf)!

H220 – Extremely flammable gas.

H280 – Contains gas under pressure; may explode if heated.

P210 – Keep away from heat, sparks, open flames and other ignition sources. No smoking.

P377 – Leaking gas fire: Do not extinguish, unless leak can be stopped safely.

P381 – Eliminate all ignition sources if safe to do so.

P403 – Store in a well-ventilated place.



#### Warning of electrical voltage

Work on the electrical components must only be carried out by an authorised specialist company!



#### Warning of electrical voltage

Before any work on the device, remove the mains plug from the mains socket!

Do not touch the mains plug with wet or damp hands. Hold onto the mains plug while pulling the power cable out of the mains socket.



#### Warning of electrical voltage

Risk of electric shock!

The device does not have the appropriate protection class for use in wet rooms.

There is a risk of electric shock!

Never use the device in wet rooms (e.g. in bathrooms and laundry rooms) and never immerse the device in water!



#### Warning

Dangers can occur at the device when it is used by untrained people in an unprofessional or improper way! Observe the personnel qualifications!



#### Warning

The device is not a toy and does not belong in the hands of children.



#### Warning

Risk of suffocation!

Do not leave the packaging lying around. Children may use it as a dangerous toy.



#### Warning

Risk of death due to suspended loads!

Make sure that nobody is situated in the immediate proximity.

#### Note

Do not operate the device without an inserted air filter! Without the air filter, the inside of the device will be heavily contaminated. This could reduce the performance and result in damage to the device.

### Behaviour in the event of an emergency

1. Switch the device off.
2. Disconnect the device from the mains feed-in: Hold onto the mains plug while pulling the power cable out of the mains socket.
3. Do not reconnect a defective device to the mains.

**Information about the device**

**Device description**

The device's primary purpose is room cooling and spot cooling. The effect of spot cooling is that the cooled room air is directed to a specific point or area. Moreover, the device provides the possibility of circulating the room air without cooling it. When used in the dehumidification mode, the device can furthermore additionally be used to dehumidify the room air. The device is operated via the control panel at the device. The device cools the room air by withdrawing warmth. The refrigerant cools down the air coming from the room and in doing so absorbs the heat. The cooled air is supplied via the cold air ducts into the room where the device is positioned. Water vapour contained in the room air precipitates on the evaporator fins as condensation or rime. The condensate is transported to the condensation tank.

**Device depiction**

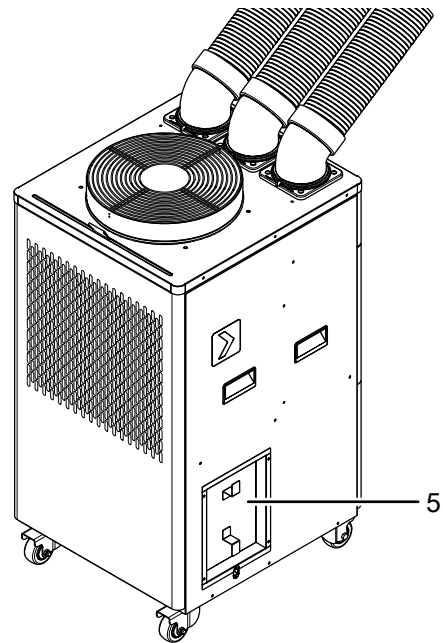
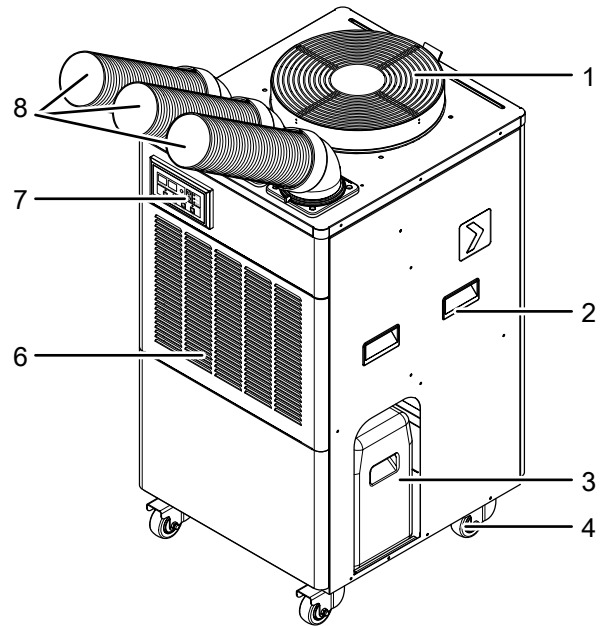

No.	Designation
1	Hot air outlet
2	Transport handle
3	Condensation tank
4	Wheels (with parking brake)
5	Cable holder
6	Air inlet with air filter
7	Control panel
8	Cold air duct

## Transport and storage

### Note

If you store or transport the device improperly, the device may be damaged.

Note the information regarding transport and storage of the device.

### Transport

Please note that additional transport regulations might apply to devices containing flammable refrigerants. The equipment's arrangement and the maximum number of components to be transported together can be gathered from the applicable transport regulations.

To make the device easier to transport, it is fitted with wheels.

To make the device easier to transport, it is fitted with a carry handle.

**Before** transporting the device, observe the following:

- Switch the device off.
- Hold onto the mains plug while pulling the power cable out of the mains socket.
- Drain the remaining condensate from the device.
- Do not use the power cable to drag the device.
- Only wheel the device on firm and level surfaces.

**While** transporting the device, observe the following:

- Only transport the device in an upright position.

**After** transporting the device, proceed as follows:

- Set up the device in an upright position after transport.
- Apply and lock the brakes at the wheels again.

### Storage

**Before** storing the device, proceed as follows:

- Clean the condensation tank and/or the condensation drain hose if necessary (see chapter Maintenance).
- Drain the remaining condensate from the device.
- Hold onto the mains plug while pulling the power cable out of the mains socket.

When the device is not being used, observe the following storage conditions:

- Only store the device in a room measuring more than 15 m<sup>2</sup>.
- Only position the device in rooms where there is no source of ignition (e.g. open flames, an active gas appliance or an electric heater).
- Store the device in a dry location and protected from frost and heat.
- Store the device in an upright position where it is protected from dust and direct sunlight.
- If required, use a cover to protect the device from invasive dust.

- Place no further devices or objects on top of the device to prevent it from being damaged.

## Assembly and start-up

### Scope of delivery

- 1 x device
- 3 x Cold air duct
- 3 x Flue pipe
- 1 x Air filter
- 1 x Condensation tank
- 1 x manual

### Unpacking the device

1. Open the cardboard box and take the device out.
2. Completely remove the packaging.
3. Fully unwind the power cable. Make sure that the power cable is not damaged and that you do not damage it during unwinding.

### Start-up

When positioning the device, observe the minimum distance from walls or other objects as described in the Technical data chapter.

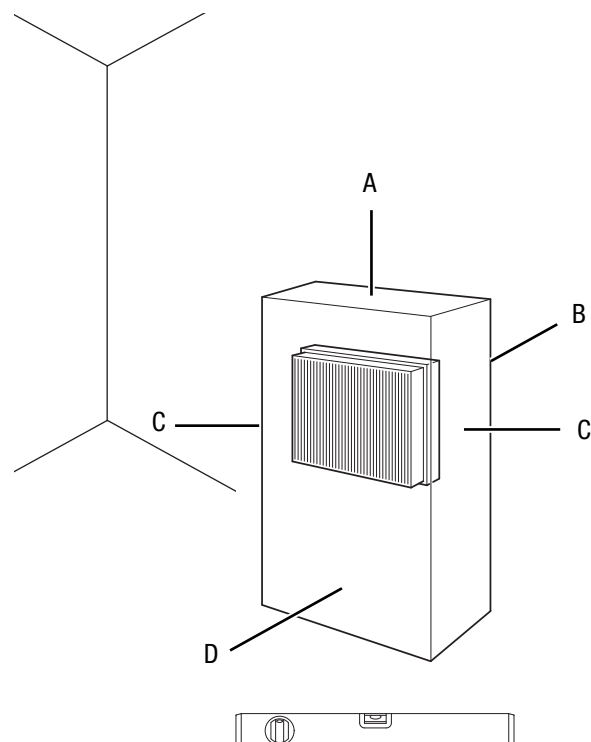

- Only position the device in rooms where potentially leaking refrigerant cannot accumulate.
- Only position the device in rooms where there is no source of ignition (e.g. open flames, an active gas appliance or an electric heater).

- Before restarting the device, check the condition of the power cable. If there are doubts as to the sound condition, contact the customer service.
- Only put up the device in an upright, stable position on firm ground.
- Do not create tripping hazards when laying the power cable or other electric cables, especially when positioning the device in the middle of the room. Use cable bridges.
- Make sure that extension cables are completely unrolled.
- Keep air inlets and outlets as well as the exhaust air hose connection free.
- Make sure that no curtains or other objects interfere with the air flow.

**Inserting the condensation tank**

**Note**

Condensate is formed during operation and must be collected with the condensation tank. Before commissioning, make sure that the condensation tank is correctly inserted. Place the opening of the condensation tank underneath the condensate outlet inside the device (see figure). Operating the device with a condensation drain hose is also possible.

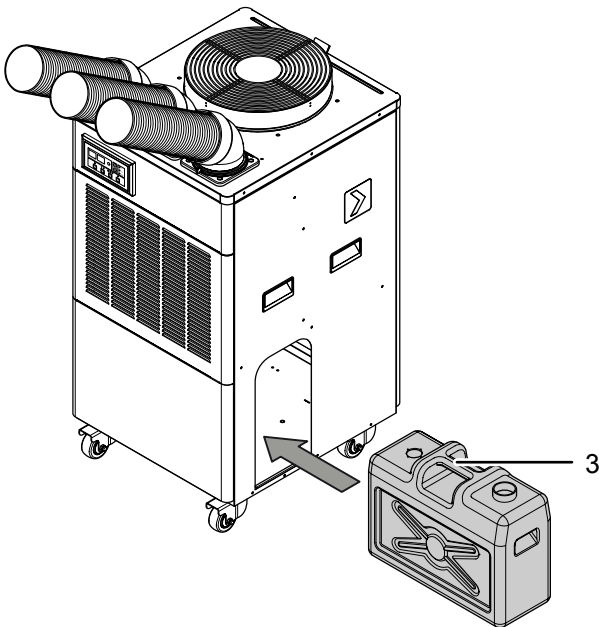

**Connecting the cold air duct**

For spot cooling operation and room air cooling, a cold air duct (8) must be connected.

1. Place the angle flange (9) on the bayonet coupling (10).
2. Turn the angle flange (9) to the right until the angle flange (9) engages.
3. Place the cold air duct (8) on the angle flange (9).
4. Turn the cold air duct (8) to the right until the cold air duct (8) engages.

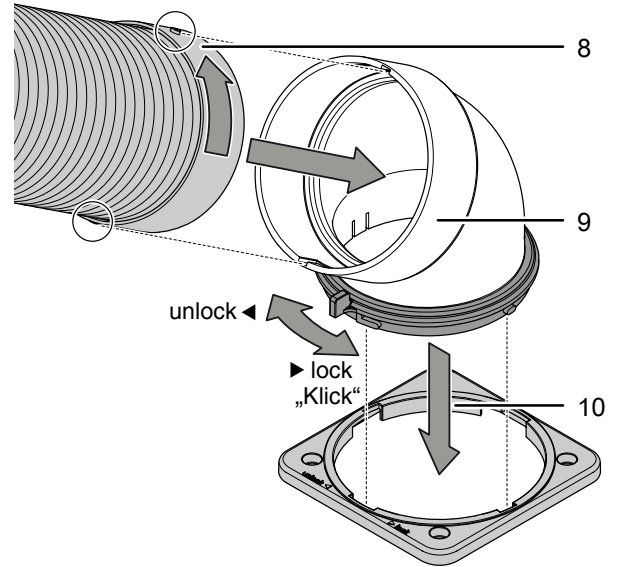



### Connecting the hot air duct

The hot air duct (11) can be connected to the device before use. The device can also be operated without a hot air duct (11).

A hot air duct (11) is not included in the scope of delivery.

1. Screw the hot air duct (11) onto the device.

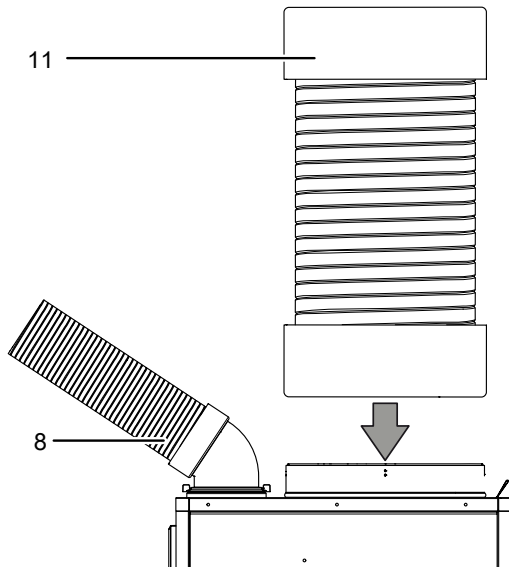

### Aligning the air ducts

The cold air duct (8) can be adjusted by 360°. In addition, the cold air duct can be adjusted upwards and downwards by 150°.

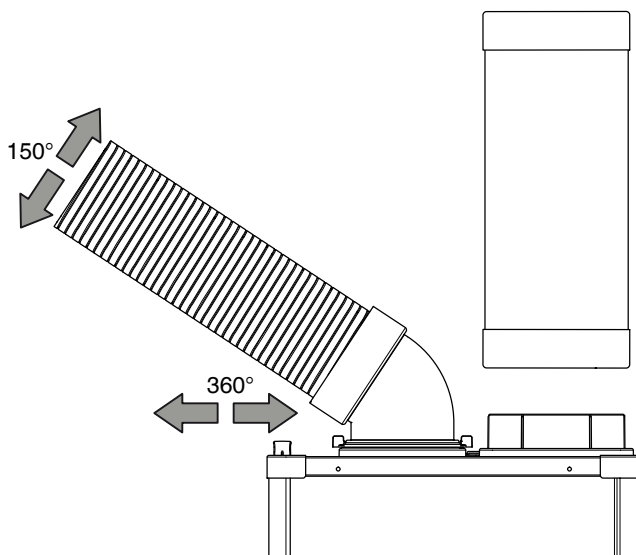

### Extending the hot air duct (optional)

#### Note

Connected ducts must not exceed a length of 3 m.

1. Cut the air duct to size or shorten or extend it as required.  
⇒ The diameter of the duct to be extended must be 380 mm.
2. Screw the duct to be extended onto the other duct while performing a rotating movement to the right.
3. Wrap sturdy tape around the point where the ducts intersect.

### Inserting the air filter

#### Note

Do not operate the device without an inserted air filter! Without the air filter, the inside of the device will be heavily contaminated. This could reduce the performance and result in damage to the device.

Make sure that the air filter is installed before switching the device on.

1. If the air filter (6) has not already been inserted, push the air filter (6) into the designated recess.

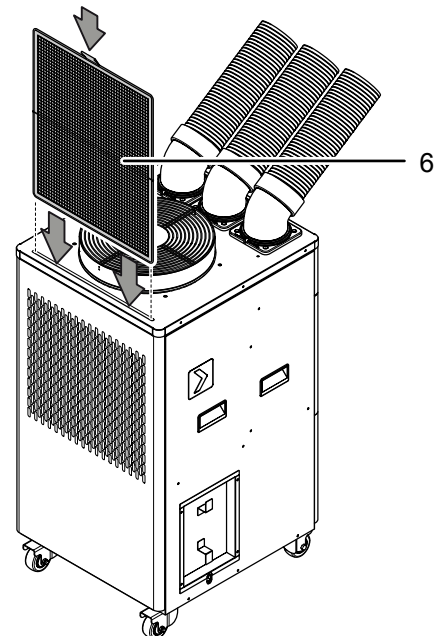

**Installation**

**Note**

The opening of the hot air duct in the outdoor area should be positioned so that it is rainproof and preventing any backflow, or so that it is bent towards the bottom.

The hot air duct (11) can be positioned into the outdoor area, thus allowing the hot exhaust air to be directed towards the outside for room air cooling.

The cold air duct (8) must be directed at the spot or area to be cooled (see “Operation” chapter).

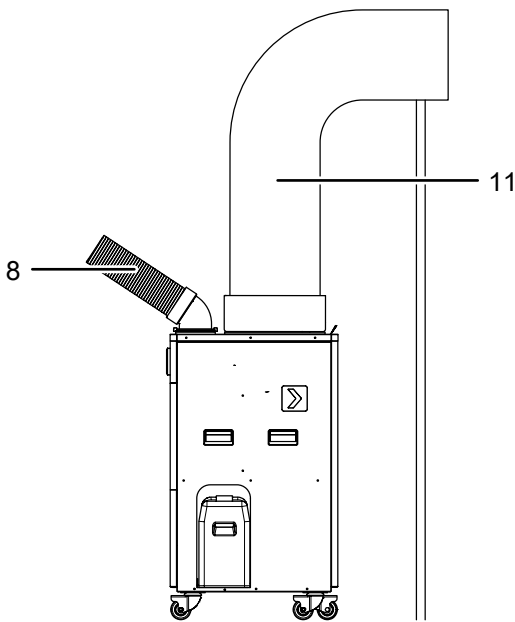

**Operation**

- Avoid open doors and windows.

**Control panel**

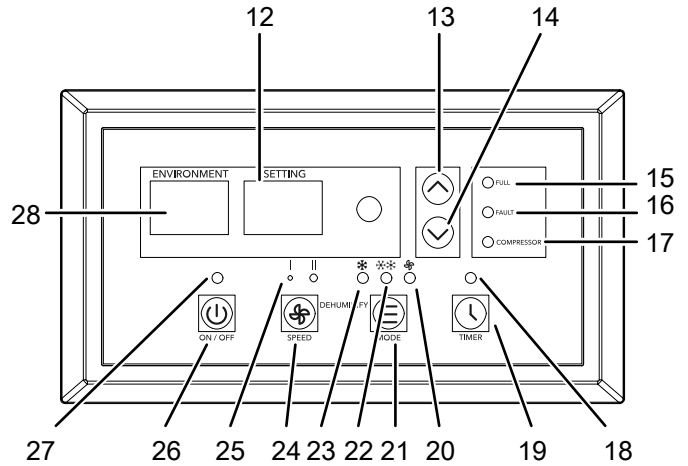

No.	Designation	Meaning
12	Segment display	Indication of target temperature Indication of the number of hours during timer programming Display of error codes tc and CO
13	Increase value button	Increasing the target temperature for cooling For increasing the number of hours when programming the timer
14	Decrease value button	Reducing the target temperature for cooling For reducing the number of hours when programming the timer
15	Condensation tank full LED	Illuminated when the condensation tank is full.
16	Fault LED	Is illuminated if an error message is displayed (see also chapter “Errors and faults”)
17	Compressor LED	Is illuminated when the compressor is in operation
19	Timer button	Switching the timer function on or off
18	Timer LED	Is illuminated when the timer is activated.

No.	Designation	Meaning
20	Ventilation LED	Illuminated when <i>ventilation</i> mode is activated
21	Mode button	Selecting the operating mode: <i>Room air cooling</i> <i>Spot cooling operation</i> <i>Ventilation</i> <i>Dehumidification</i>
22	Spot cooling mode LED	Is lit when the <i>Spot cooling</i> mode is activated
23	Room air cooling LED	Is lit when the <i>Room air cooling</i> mode is activated Flashes when <i>Dehumidification</i> mode is activated
24	Speed button	Setting the fan speed
25	Fan speed LEDs	Indication of the fan speed I = low II = high
26	On/off button	Switching the device on or off
27	On/off LED	Operating control lamp
28	Environment segment indication	Indicates the actual temperature. Indicates error codes E1, E2 and E3



### Warning of electrical voltage

Risk of electric shock!

The device does not have the appropriate protection class for use in wet rooms.

There is a risk of electric shock!

Never use the device in wet rooms (e.g. in bathrooms and laundry rooms) and never immerse the device in water!

### Switching the device on

- Once you have completely installed the device as described in the Start-up chapter, you can switch it on.
- Press the *On/Off* button (26).
  - ⇒ The device starts in the *Room air cooling* mode.
  - ⇒ The *Room air cooling* LED (23) is illuminated.

### Setting the operating mode

- Room air cooling
- Spot cooling operation
- Ventilation
- Dehumidification

### Room air cooling

In the *Room air cooling* mode the room will be cooled down to the desired target temperature.

The temperature to be set is the room temperature and is measured at the air inlet.

- Press the *Mode* button(21) until the *Room air cooling* LED (23) is lit.
- Press the *Decrease value* (14) or *Increase value* button (13) to select the desired target temperature. The temperature can be adjusted in increments of 1 °C in a range between 15 °C and 35 °C.
  - ⇒ The desired target temperature is indicated on the segment display (12).
- Press the *fan speed* button (24) to set the desired fan stage.
  - ⇒ The *fan speed* LED (25) for the desired fan stage will be illuminated.
  - ⇒ The *Room air cooling* LED (23) will be illuminated to indicate *cooling* mode.

### Spot cooling operation

In the *Spot cooling mode*, cold air is blown out and a spot or area in the room is cooled down by targeted focussing of the cold air ducts.

- Press the *Mode* button(21) until the *Spot air cooling* LED (22) is lit.
- Press the *Increase value* (14) or *Decrease value* button (13) to select the desired target temperature. The temperature can be adjusted in increments of 1 °C in a range between 10 °C and 20 °C.

### Ventilation

- Press the *Mode* button (21) until the LED for *ventilation* (20) lights up.
- Press the *fan speed* button (24) to set the desired fan speed.
  - ⇒ The LED for the selected fan speed (25) will be illuminated.

### Dehumidification

In *dehumidification* mode the humidity level in the room is reduced.

The target temperature can be set to obtain a cooling effect during dehumidification.

- Press the *Fan speed* button(24) and the *Mode* button (21) simultaneously for 3 seconds until an acoustic signal sounds and the *Room air cooling* LED (23) flashes.
  - ⇒ *Dehumidification* mode is selected.
  - ⇒ In the segment indication, the actual temperature is shown on the left-hand side and the target temperature is shown on the right-hand side.
- To exit the *Dehumidification* mode, keep the *Fan speed* button (24) and *Mode* button (21) pressed simultaneously for 3 seconds.

### Setting the timer

The timer can be programmed in increments of 0.5 hours (0.5 h to 10 h) and in increments of 1 hour (10 h to 24 h).

The function can be set in all operating modes.

The timer has two modes of operation:

- automatic switch-on upon expiry of a preset number of hours
- automatic switch-off upon expiry of a preset number of hours

#### Note

The device must not be left unattended in a freely accessible room with an activated timer.

### Automatic switch-on

- ✓ The device is switched off.
- 1. Press the *Timer* button (19) to activate the timer.
- 2. Press the *decrease value* (14) or *increase value* button (13) to select the desired number of hours until automatic switch-on.
  - ⇒ The segment display (12) continuously indicates the number of hours until automatic switch-on.
  - ⇒ After the predefined time, the device switches itself on.

Notes regarding automatic switch-on:

- If the device is disconnected from the power supply, all settings for automatic switch-on are deleted.
- Manually switching the device on disables the automatic switch-on function.
- If you select **0** hours, the timer will be off.

### Automatic switch-off

- ✓ The device is switched on.
- 1. Press the *Timer* button (19) to activate the timer.
- 2. Press the *decrease value* (14) or *increase value* button (13) to select the desired number of hours until automatic switch-off.
  - ⇒ The number of hours until automatic switch-on will be indicated on the segment display (12) for approx. 3 seconds.
  - ⇒ After the predefined time, the device switches itself off.

Notes regarding automatic switch-off:

- If the device is disconnected from the power supply, all settings for automatic switch-on are deleted.
- Manually switching the device off disables the automatic switch-off function.

### Connecting the condensation hose

The device can be operated with a condensation hose (29).

- ✓ A suitable condensation hose is provided (diameter 16 mm).
- 1. Remove the condensation tank from the device.
- 2. Connect the condensation hose (29) to the condensation connection (30) in the interior of the device.

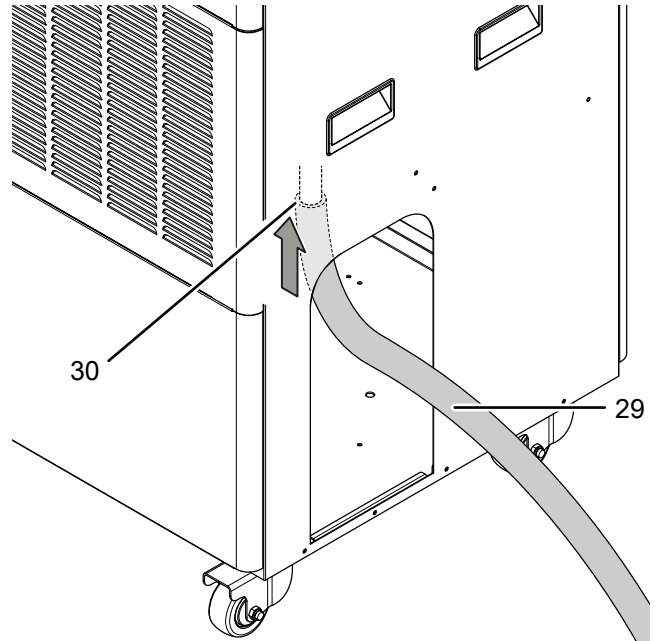

- 3. Guide the other hose end to a suitable drain or sufficiently dimensioned collection container. To ensure that the condensate can run off, the condensation drain hose must not be kinked, nor should it have to overcome an uphill incline towards the drain.

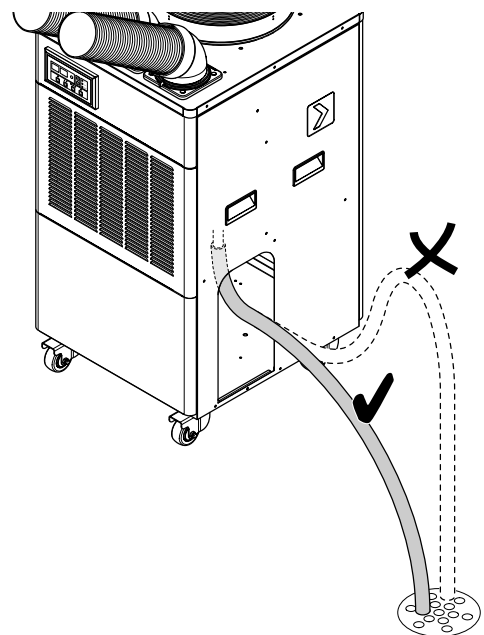

## Shutdown



### Warning of electrical voltage

Do not touch the mains plug with wet or damp hands.

- Switch off the device by pressing the *On/Off* button (26).
- Hold onto the mains plug while pulling the power cable out of the mains socket.
- Clean the device according to the Maintenance chapter.
- Empty the condensation tank, if need be.
- Store the device according to the Transport and storage chapter.

## Errors and faults

The device has been checked for proper functioning several times during production. If malfunctions occur nonetheless, check the device according to the following list.

### The device does not start:

- Check the power connection.
- Check the power cable and mains plug for damage. If you notice damages, do not try to take the device back into operation.

If the supply cord is damaged, it must be replaced by the manufacturer, its service agent or similarly qualified persons in order to avoid a hazard.

- Check the on-site fusing.
- Observe the operating temperature according to the chapter Technical annex.
- Wait for 10 minutes before restarting the device. If the device is not starting, have the electrics checked by a specialist company or by Trotec.

### The device works with reduced or no cooling capacity:

- Check the air filter(s) for dirt. If necessary, clean or replace the air filter(s).
- Check the minimum distance to walls or other objects. Position the device a little more in the room's centre if required.
- Check the temperature setting at the device. Reduce the set temperature if it is higher than the room temperature.

### The device is loud or vibrates:

- Check whether the device is set up in a stable and upright position.

### Condensate is leaking from the basic device:

- Check the device for leaks.

### The compressor does not start:

- Check whether the overheating protection of the compressor has tripped. Disconnect the device from the mains and let it cool down for approx. 10 minutes before reconnecting it.
- The compressor may start up with a delay of 3 minutes, as it is provided with an internal protection against direct restart.

### The device gets very warm, is loud or is losing performance:

- Check the air inlets and air filters for dirt. Remove external dirt.
- From the outside, check the device for dirt (see chapter Maintenance). If the inside of the device is dirty, have it cleaned by a specialist company for cooling and air-conditioning or by Trotec.

### Note

Wait for at least 3 minutes after maintenance and repair work. Only then switch the device back on.

### The device still does not operate correctly after these checks:

Please contact the customer service. If necessary, bring the device to a specialist company for cooling and air-conditioning or to Trotec for repair.

## Error codes

The following error messages can be displayed on the segment displays (12) and (28):

Error code	Cause	Solution
tc	Coil heat exchanger	Disconnect the device briefly from the mains. Should the error still be displayed after the restart, please contact the customer service
C0	Overload of the compressor, current or pressure overload protection	Disconnect the device briefly from the mains. Should the error still be displayed after the restart, please contact the customer service
E1	Malfunction of the room temperature sensor ( <i>room sensor</i> )	Replace the room temperature sensor ( <i>room sensor</i> )
E2	Malfunction of the temperature sensor at the air outlet ( <i>pipe sensor</i> )	Replace the temperature sensor at the air outlet ( <i>pipe sensor</i> )
E3	Malfunction of the sensor for the sensor lead of the vaporizer ( <i>out air sensor</i> )	Replace the sensor for the sensor lead of the vaporizer ( <i>out air sensor</i> )

## Maintenance

## Maintenance intervals

Maintenance and care interval	before every start-up	as needed	at least every 2 weeks	at least every 4 weeks	at least every 6 months	at least annually
Check air inlet and outlet for dirt and foreign objects and clean if necessary	X			X		
Check air inlets and outlets for dirt and foreign objects and clean if necessary	X			X		
Clean the exterior		X				X
Visually check the inside of the device for dirt		X				X
Check the air filter for dirt and foreign objects and clean or replace if necessary	X		X			
Replace the air filter					X	
Check for damage	X					
Check the attachment screws		X				X
Test run						X
Empty and clean the condensation tank and/or drain hose		X				

## Maintenance and care log

Device type: .....

Device number: .....

Maintenance and care interval	1	2	3	4	5	6	7	8	9	10	11	12	13	14	15	16
Check air inlets and outlets for dirt and foreign objects and clean if necessary																
Check the air filter for dirt and foreign objects and clean or replace if necessary																
Check air inlets and outlets for dirt and foreign objects and clean if necessary																
Clean the exterior																
Visually check the inside of the device for dirt																
Replace the air filter																
Check for damage																
Check the attachment screws																
Test run																
Empty and clean the condensation tank and/or drain hose																

1. Date: ..... Signature: .....	2. Date: ..... Signature: .....	3. Date: ..... Signature: .....	4. Date: ..... Signature: .....
5. Date: ..... Signature: .....	6. Date: ..... Signature: .....	7. Date: ..... Signature: .....	8. Date: ..... Signature: .....
9. Date: ..... Signature: .....	10. Date: ..... Signature: .....	11. Date: ..... Signature: .....	12. Date: ..... Signature: .....
13. Date: ..... Signature: .....	14. Date: ..... Signature: .....	15. Date: ..... Signature: .....	16. Date: ..... Signature: .....

**Activities required before starting maintenance**



**Warning of electrical voltage**

Do not touch the mains plug with wet or damp hands.

- Switch the device off.
- Hold onto the mains plug while pulling the power cable out of the mains socket.



**Warning of electrical voltage**

**Tasks which require the device to be opened must only be carried out by authorised specialist companies or by Trotec.**

**Refrigerant circuit**



**Danger**

**Refrigerant 2,3,3,3-Tetrafluoropropene (R1234yf)!**

H220 – Extremely flammable gas.

H280 – Contains gas under pressure; may explode if heated.

P210 – Keep away from heat, sparks, open flames and other ignition sources. No smoking.

P377 – Leaking gas fire: Do not extinguish, unless leak can be stopped safely.

P381 – Eliminate all ignition sources if safe to do so.

P403 – Store in a well-ventilated place.

- The entire refrigerant circuit is a maintenance-free, hermetically sealed system and may only be maintained or repaired by specialist companies for cooling and air-conditioning or by Trotec.

**Safety signs and labels on the device**

Check the safety signs and labels attached to the device at regular intervals. Replace illegible safety signs!

**Cleaning the housing**

Clean the housing with a soft, damp and lint-free cloth. Make sure that no moisture enters the housing. Protect electrical components from moisture. Do not use any aggressive cleaning agents such as cleaning sprays, solvents, alcohol-based or abrasive cleaners to dampen the cloth.

**Visual inspection of the inside of the device for dirt**

1. Remove the air filter.
2. Use a torch to illuminate the openings of the device.
3. Check the inside of the device for dirt.
4. If you see a thick layer of dust, have the inside of the device cleaned by a specialist company for cooling and air-conditioning or by Trotec.

5. Put the air filter back in.

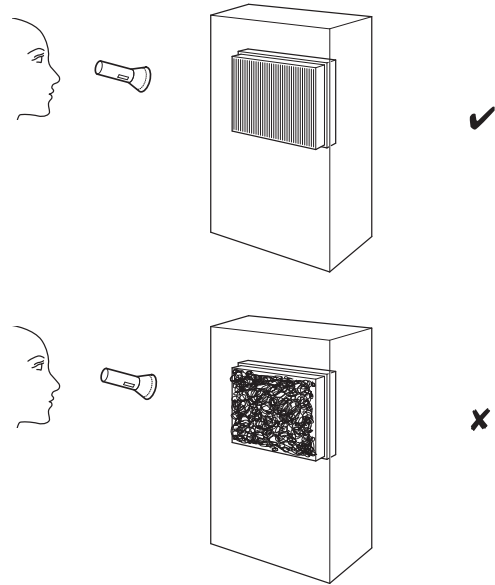

**Cleaning the air filter**

The air filter has to be cleaned as soon as it is dirty. This is brought to light e.g. by a reduced capacity (see chapter Errors and faults).



**Warning**

Ensure that the air filter is not worn or damaged. The corners and edges of the air filter must not be deformed or rounded. Before reinserting the air filter, make sure that it is undamaged and dry!

1. Remove the air filter from the device.

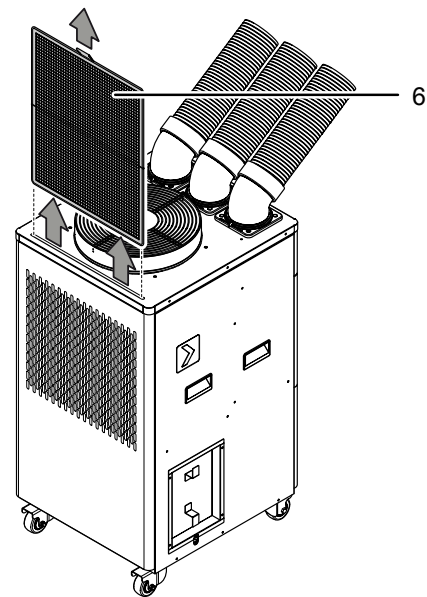

2. Clean the filter using a slightly damp, soft, lint-free cloth. If the filter is heavily contaminated, clean it with warm water mixed with a neutral cleaning agent.



3. Allow the filter to dry completely. Do not insert a wet filter into the device!
4. Reinsert the air filter into the device.

### Condensate discharge (manual draining)

In *cooling* mode condensate is formed, which is mostly discharged via the exhaust air.

The remaining condensate is collected in a container within the housing. The condensate ought to be drained regularly.

If too much condensate accumulates, the device switches off and indicates this via the *Condensation tank full* LED (15). In addition, an acoustic signal is emitted.

1. Pull the condensation tank (3) out of the designated recess.

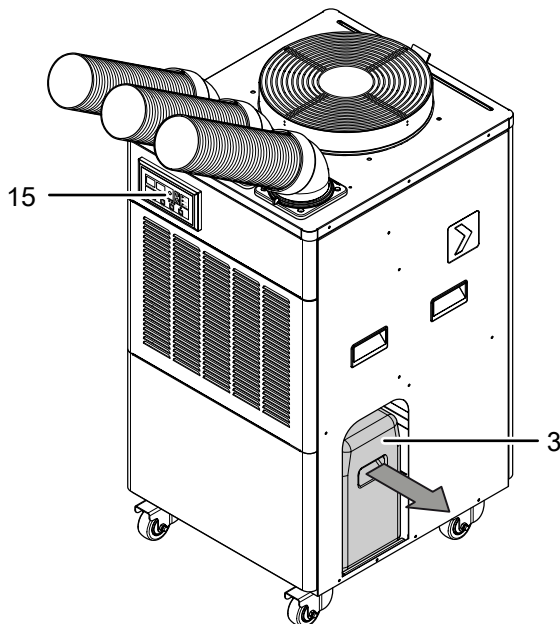

2. Empty the condensation tank.
3. Refit the emptied condensation tank into the device.
  - ⇒ The *condensation tank full* LED (15) goes out once you restart the device.

### Activities required after maintenance

If you want to continue using the device:

- Reconnect the device to the mains.

If you do not intend to use the device for a considerable time:

- Store the device according to the Transport and storage chapter.

## Technical annex

### Technical data

Model	PT 5300 SP	PT 5300 SP UK
Article number	1.210.001.058	1.210.011.058
Cooling capacity	5.3 kW	5.3 kW
Dehumidification performance	2.70 l/h	2.70 l/h
Operating range	18 °C to 45 °C	18 °C to 45 °C
Temperature setting range	0 °C to 35 °C	0 °C to 35 °C
Max. air volume flow	800 m <sup>3</sup> /h	800 m <sup>3</sup> /h
Mains supply	220 V – 240 V / 50 Hz	240 V / 50 Hz
Nominal current	10 A	10 A
Type of protection	IPX0	IPX0
Max. power input (cooling operation)	2.2 kW	2.2 kW
Sound pressure level at a distance of 1 m	65 dB(A)	65 dB(A)
Refrigerant	R1234yf	R1234yf
Amount of refrigerant	950 g	950 g
GWP factor	4	4
CO <sub>2</sub> equivalent	0.0038 t	0.0038 t
Pressure suction side	1 MPa	1 MPa
Outlet side pressure	2.5 MPa	2.5 MPa
Max. permissible pressure	2.5 MPa	2.5 MPa
Condensation tank capacity	25 l	25 l
Dimensions (length x width x height)	560 x 625 x 1135 mm	560 x 625 x 1135 mm
Minimum distance to walls and other objects:		
top:	90 cm	90 cm
sides:	30 cm	30 cm
front:	30 cm	30 cm
rear:	30 cm	30 cm
Weight	95 kg	95 kg

**Circuit diagram**

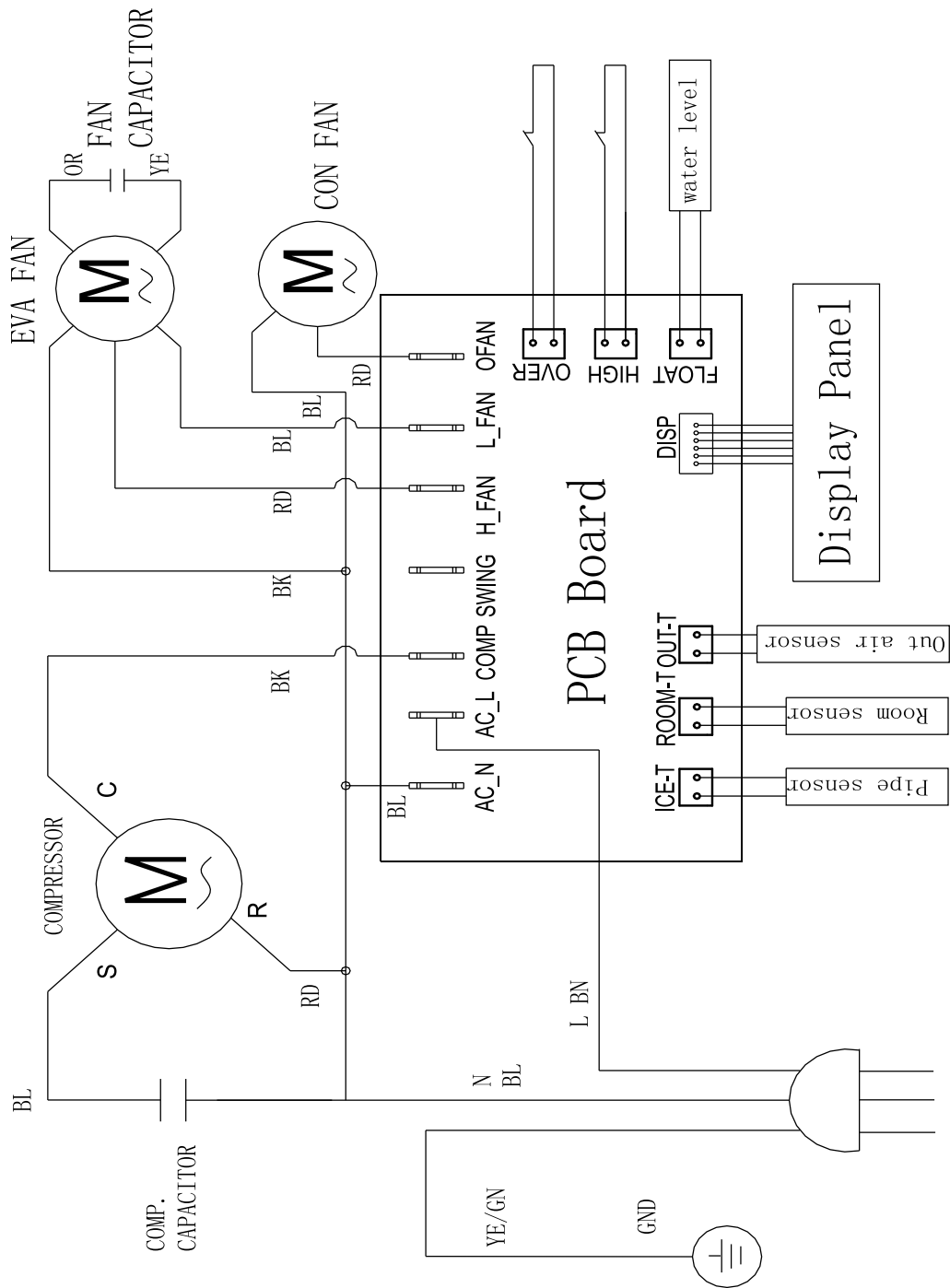

**Overview and list of spare parts**

**Note:** The position numbers of the spare parts differ from those describing the positions of other parts mentioned in this operating manual.

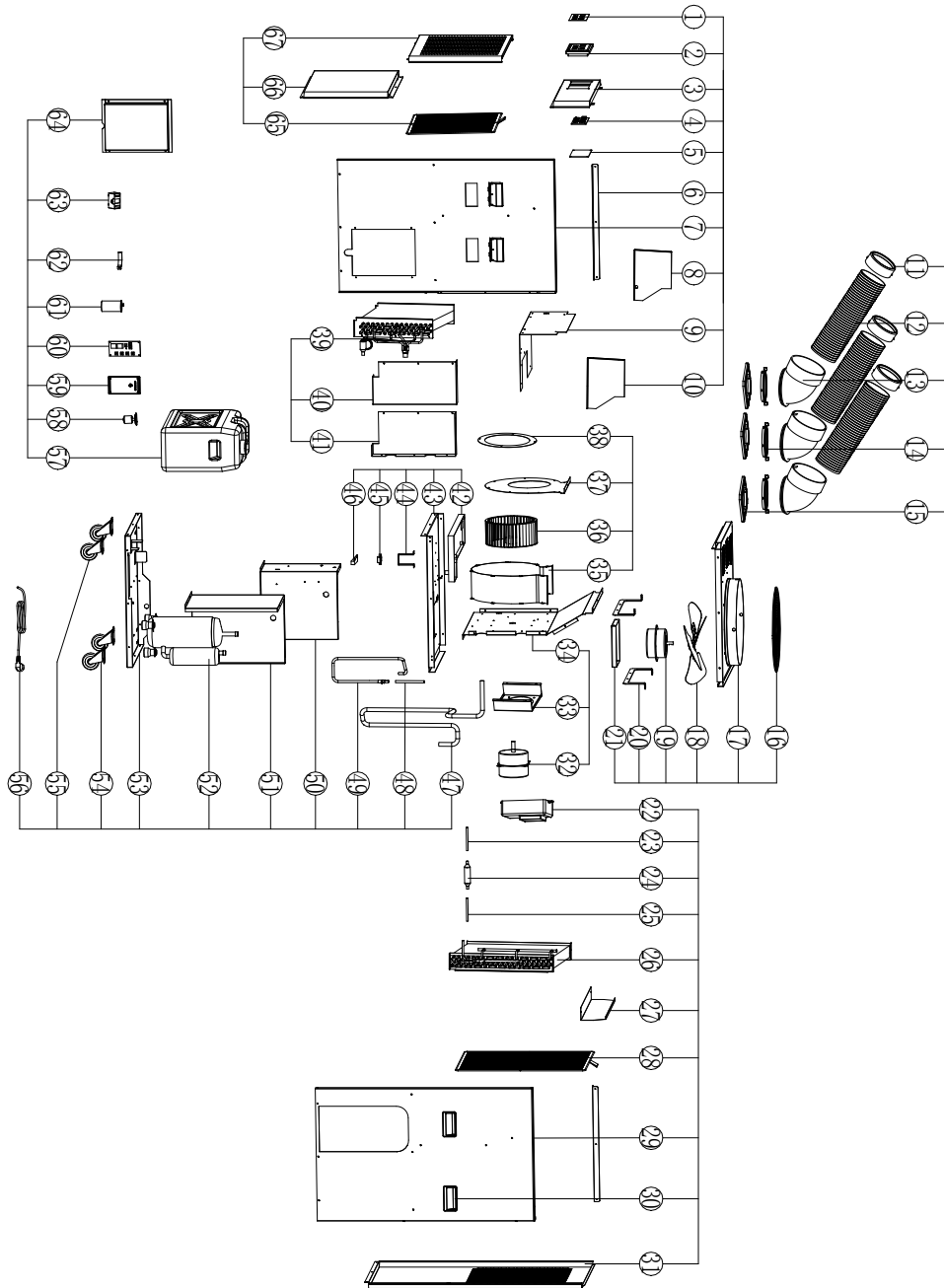

No.	Spare part	No.	Spare part	No.	Spare part
1	Control panel label	24	Drying filter	47	Suction pipe
2	Control plastic panel	25	Filter-in-pipe	48	Filling pipe
3	Control panel	26	Condenser ASM	49	Discharge pipe
4	Display PCB	27	Bracket rear shell	50	Control box plate
5	Rear cover of display	28	Rear air filter	51	Support plate
6	Bracket of side plate	29	Right side plate	52	Compressor
7	Left side plate	30	Handle	53	Chassis asm.
8	Left air duct plate	31	Rear shell	54	Universal casters
9	Evaporator cover	32	Motor of evap.	55	Universal casters with lock
10	Right air duct plate	33	Bracket of evap. motor	56	Power cord and plug
11	Connector 1	34	Air duct front plate	57	Water tank
12	Cooling tube	35	Air duct frame plate	58	Water level switch
13	Tube 1	36	Wind mill 1	59	Power board bracket
14	Tube 1 fix frame	37	Air duct back plate	60	Power supply board
15	Tube 1 fix base	38	Guide plate	61	Compressor capacitor
16	Metal mesh	39	Evaporator ASM	62	Capacitor bracket
17	Top coverl	40	Left holder of evap.	63	Fan capacitor
18	Fan blade	41	Right holder of evap.	64	Cover of control box
19	Motor of cond.	42	Water tray	65	Front air filter
20	Bracket of con. motor	43	Middle partition	66	Bottom cover front shell
21	Holder of con. motor	44	Bracket water level	67	Front shell
22	Control motor shell	45	Holder of magnetron switch		
23	Condenser-out pipe	46	Magnetron switch		

## Disposal

Always dispose of packing materials in an environmentally friendly manner and in accordance with the applicable local disposal regulations.



The icon with the crossed-out waste bin on waste electrical or electronic equipment is taken from Directive 2012/19/EU. It states that this device must not be disposed of with the household waste at the end of its life. You will find collection points for free return of waste electrical and electronic equipment in your vicinity. The addresses can be obtained from your municipality or local administration. You can also find out about other return options that apply for many EU countries on the website <https://hub.trotec.com/?id=45090>. Otherwise, please contact an official recycling centre for electronic and electrical equipment authorised for your country.

The separate collection of waste electrical and electronic equipment aims to enable the re-use, recycling and other forms of recovery of waste equipment as well as to prevent negative effects for the environment and human health caused by the disposal of hazardous substances potentially contained in the equipment.

The device is operated with fluorinated refrigerant, which can be dangerous for the environment and contribute to global warming when emitted to the atmosphere.

Further information is provided on the nameplate.

Dispose of the refrigerant appropriately and according to the national regulations.

### Only for United Kingdom

According to Waste Electrical and Electronic Equipment Regulations 2013 (SI 2013/3113) (as amended) devices that are no longer usable must be collected separately and disposed of in an environmentally friendly manner.

## Declaration of conformity

Declaration of conformity in accordance with the EC Machinery Directive 2006/42/EC, Annex II, Part 1, Section A

We – Trotec GmbH – declare in sole responsibility that the product designated below was developed, constructed and produced in compliance with the requirements of the EC Machinery Directive in the version 2006/42/EC.

**Product model / Product:** PT 5300 SP

**Product type:** spot cooling air conditioning unit

**Year of manufacture as of:** 2023

### Relevant EU directives:

- 2011/65/EU
- 2014/30/EU

### Applied harmonised standards:

- EN 60335-2-40:2003/A13:2012

### Applied national standards and technical specifications:

- EN IEC 55014-1:2021
- EN IEC 55014-2:2021
- EN IEC 61000-3-2:2019
- EN IEC 61000-3-2:2019/A1:2021
- EN IEC 61000-3-11:2019
- EN 60335-1:2012/A2:2019
- EN 62233:2008

### Manufacturer and name of the authorised representative of the technical documentation:

Trotec GmbH

Grebener Straße 7, D-52525 Heinsberg

Phone: +49 2452 962-400

E-mail: [info@trotec.de](mailto:info@trotec.de)

Place and date of issue:

Heinsberg, 12.01.2023



Joachim Ludwig, Managing Director

Trotec GmbH

Grebener Str. 7  
D-52525 Heinsberg

☎ +49 2452 962-400

☎ +49 2452 962-200

✉ [info@trotec.com](mailto:info@trotec.com)

[www.trotec.com](http://www.trotec.com)